

1973

Reactions of chlorosulfonyl isocyanate with heterocyclopentadienes and small ring olefins

Robert Joseph Rogido
Iowa State University

Follow this and additional works at: <https://lib.dr.iastate.edu/rtd>

 Part of the [Organic Chemistry Commons](#)

Recommended Citation

Rogido, Robert Joseph, "Reactions of chlorosulfonyl isocyanate with heterocyclopentadienes and small ring olefins " (1973).
Retrospective Theses and Dissertations. 5960.
<https://lib.dr.iastate.edu/rtd/5960>

This Dissertation is brought to you for free and open access by the Iowa State University Capstones, Theses and Dissertations at Iowa State University Digital Repository. It has been accepted for inclusion in Retrospective Theses and Dissertations by an authorized administrator of Iowa State University Digital Repository. For more information, please contact digirep@iastate.edu.

INFORMATION TO USERS

This material was produced from a microfilm copy of the original document. While the most advanced technological means to photograph and reproduce this document have been used, the quality is heavily dependent upon the quality of the original submitted.

The following explanation of techniques is provided to help you understand markings or patterns which may appear on this reproduction.

1. The sign or "target" for pages apparently lacking from the document photographed is "Missing Page(s)". If it was possible to obtain the missing page(s) or section, they are spliced into the film along with adjacent pages. This may have necessitated cutting thru an image and duplicating adjacent pages to insure you complete continuity.
2. When an image on the film is obliterated with a large round black mark, it is an indication that the photographer suspected that the copy may have moved during exposure and thus cause a blurred image. You will find a good image of the page in the adjacent frame.
3. When a map, drawing or chart, etc., was part of the material being photographed the photographer followed a definite method in "sectioning" the material. It is customary to begin photoing at the upper left hand corner of a large sheet and to continue photoing from left to right in equal sections with a small overlap. If necessary, sectioning is continued again — beginning below the first row and continuing on until complete.
4. The majority of users indicate that the textual content is of greatest value, however, a somewhat higher quality reproduction could be made from "photographs" if essential to the understanding of the dissertation. Silver prints of "photographs" may be ordered at additional charge by writing the Order Department, giving the catalog number, title, author and specific pages you wish reproduced.
5. PLEASE NOTE: Some pages may have indistinct print. Filmed as received.

Xerox University Microfilms

300 North Zeeb Road
Ann Arbor, Michigan 48106

74-9152

ROGIDO, Robert Joseph, 1945-
REACTIONS OF CHLOROSULFONYL ISOCYANATE WITH
HETEROCYCLOPENTADIENES AND SMALL RING OLEFINS.

Iowa State University, Ph.D., 1973
Chemistry, organic

University Microfilms, A XEROX Company, Ann Arbor, Michigan

Reactions of chlorosulfonyl isocyanate with
heterocyclopentadienes and small ring olefins

by

Robert Joseph Rogido

A Dissertation Submitted to the
Graduate Faculty in Partial Fulfillment of
The Requirements for the Degree of
DOCTOR OF PHILOSOPHY

Department: Chemistry

Major: Organic Chemistry

Approved:

Signature was redacted for privacy.

In Charge of ~~Major~~ Work

Signature was redacted for privacy.

For the ~~Major~~ Department

Signature was redacted for privacy.

For the ~~Graduate~~ College

Iowa State University
Ames, Iowa

1973

TABLE OF CONTENTS

	Page
DEDICATION	iii
INTRODUCTION	1
RESULTS AND DISCUSSION	17
CONCLUSION	73
EXPERIMENTAL	83
Reactions of CSI with Cyclopropenes	84
Reactions of CSI with Heterocyclopentadienes	87
Reactions of CSI with <u>trans</u> - β -Trimethyl- silylstyrene	97
Reactions of CSI with 2-Cyclopropylpropene	100
Reactions of CSI with Diphenylmethylene- cyclopropane	106
Reactions of CSI with Cyclobutenes	108
Reinvestigation of the 1,1-Dimethyl-2,5- diphenylsilole-CSI Reaction	113
LITERATURE CITED	119
ACKNOWLEDGEMENT	124

DEDICATION

To my wife Donna

INTRODUCTION

The synthesis of chlorosulfonyl isocyanate (CSI) 1 by the reaction of sulfur trioxide with cyanogen chloride was reported by Graf in 1956 (1). Since then it has proven to be the most reactive isocyanate known. It is relatively more reactive than alkyl sulfonyl isocyanates in olefin additions by as much as 1×10^5 (2). Its highly reactive nature is due to polarization of the cumulated π system by the highly electronegative chlorosulfonyl group. Infrared investigation has shown CSI to have the expected nonlinear S-N-C bond (3).

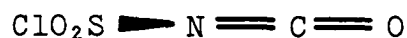
1

A wide variety of reactions have been reported for CSI among which its addition to olefins has proven to be the most interesting and synthetically useful (4). CSI reacts with olefins to yield either N-chlorosulfonyl- β -lactams 2 and/or unsaturated N-chlorosulfonyl amides 3. The NCS- β -lactams generally predominate and in many cases are the exclusive products. The initially formed NCS- β -lactam 2 may be reduced to β -lactam 4 by a variety of methods (4) or converted to unsaturated nitrile 5 by treatment with

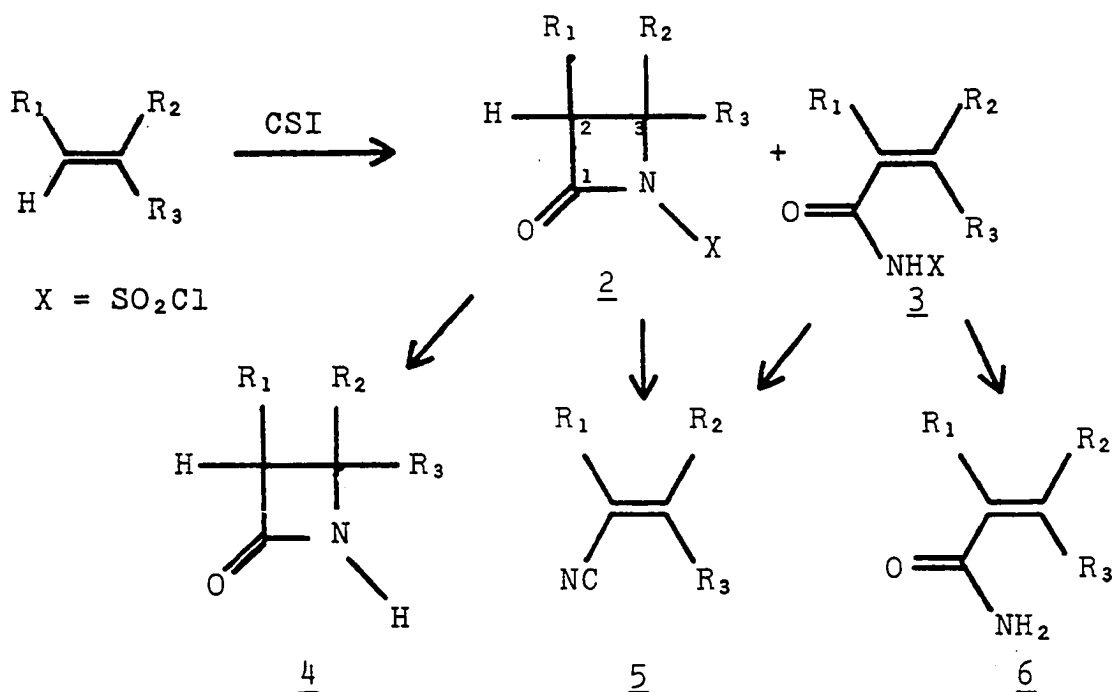

dimethylformamide (5). In cases where NCS-amide 3 is produced it may be converted to amide 6 by treatment with sodium hydroxide or converted to nitrile 5 by treatment with tertiary amines (6).

Graf proposed that reaction of CSI with olefins proceeds via direct formation of dipolar intermediate 7 (4) which could suffer ring closure forming 2 or undergo hydrogen

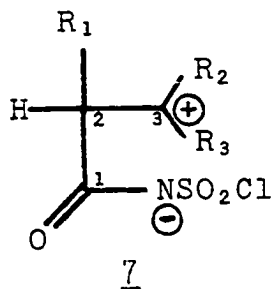

transfer leading to 3. Consistent with this proposal is the observation that in NCS- β -lactam formation the nitrogen is always attached to the carbon which can best accommodate a positive charge (Markovnikov addition).

Kinetic data also lend support to Graf's mechanism. Clauss reported (2) that CSI reacts with 1-butene, 2,3-dimethyl-2-butene and 2-methylstyrene with relative rates of 1.0, 1.6×10^4 and 8×10^4 respectively, which parallels the stability of the proposed dipolar intermediates. Clauss also observed rate increase with increasing solvent polarity. Thus, there is a rate factor of 3×10^4 between hexane and nitromethane. However, the most convincing evidence so far for Graf's mechanism is his claim that 2 and 3 form with a constant rate ratio throughout the reaction (4). This implies simultaneous formation of 2 and 3 from a common intermediate and that 2 and 3 are not in equilibrium.

Graf's mechanism seemed reasonable in light of the preceding evidence. Furthermore, the only attractive alternative, a concerted $\pi^2 + \pi^2$ cycloaddition reaction was not thermally allowed by the original Woodward-Hoffman selection rules (7). Since then, theoretical predictions and mounting experimental evidence have made the concerted pathway an attractive alternative. Woodward and Hoffman's (8) re-examination of their original selection rules led them to conclude that a $\pi^2 + \pi^2$ cycloaddition reaction would

be thermally allowed if it occurred in an antarafacial manner on one of the reactants. The requisite transition state 8 for a $\pi^2s + \pi^2a$ is highly strained and not likely to be

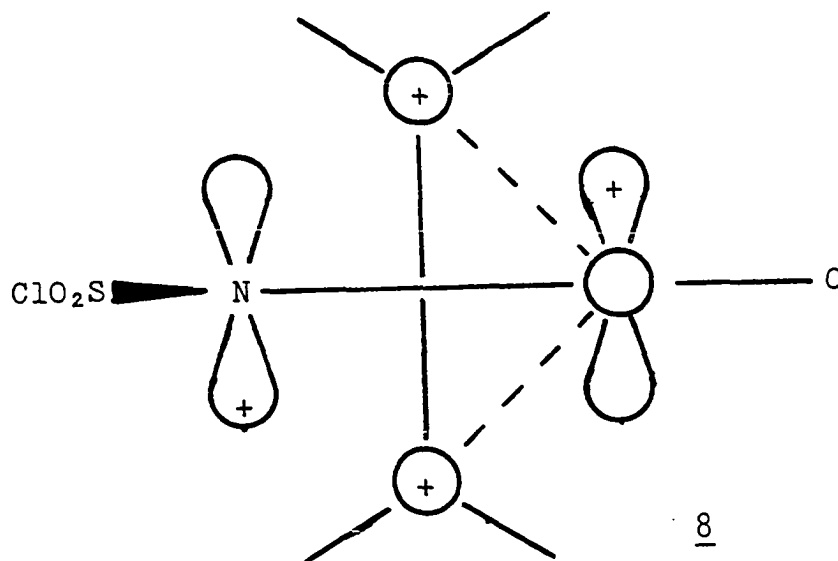

attained unless stabilized by an electrophilic orbital in the antarafacial component orthogonal to its reacting π orbital. The interaction of this orbital, which can be either a π^* orbital (ketenes and isocyanates) or an empty p orbital (vinyl cation), with the π bond of the suprafacial component is net bonding leading to stabilization of transition state 8.

Experimental evidence lending support to a concerted pathway has been rapidly accumulating. Moriconi and Kelley

(9) and subsequently Bestian *et al.* (10) have found the addition of CSI to olefins occurs stereospecifically. For example, addition of CSI to cis- β -methylstyrene (9a) gave rise exclusively to cis-lactam 10a while trans- β -methylstyrene (9b) yielded exclusively trans- β -lactam product 10b (9).

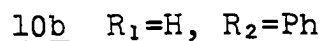
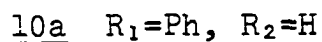
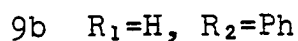
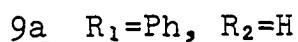
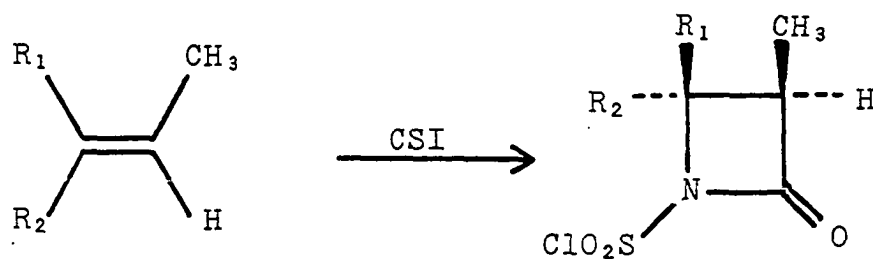

Paquette *et al.* found that cis-3,4-dimethyl-2-azetidinone (11a) undergoes cycloreversion in good yield when pyrolyzed at 600° to yield an olefin mixture comprised of 99.3% cis-2-butene (12a) (11).

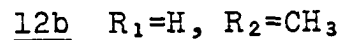
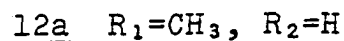
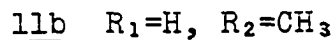
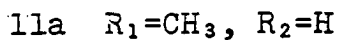
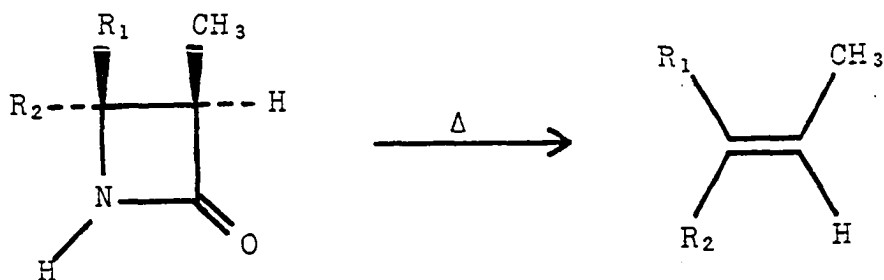

Similarly, trans-azetidinone 11b gave an olefin mixture comprised of 99.7% trans olefin 12b. A 1,4 diradical intermediate was ruled out since cycloreversion reactions involving such intermediates are known to lose their stereochemical integrity (11).

Moriconi and Crawford reported the reaction of CSI with various norbornenes and norbornadienes to give exclusively exo- β -lactam products (12). No Wagner-Meerwein rearrangement products 13 were found in any case. This is not consistent with involvement of dipolar intermediate 14.

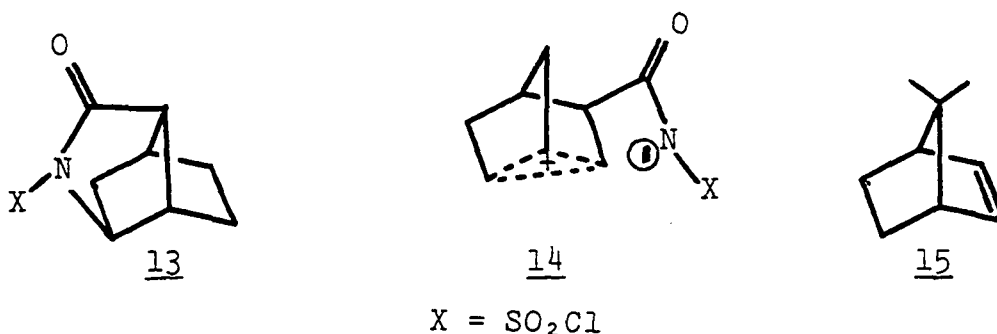

It is interesting to note that 7,7-dimethylnorbornene failed to react with CSI even under forcing conditions (12). This observation agrees with Brown and Kawakami's (13) argument that one stage additions involving cyclic transition states prefer to add exo to norbornene and endo to 7,7-dimethylnorbornene 15. In the case of 15 apparently neither exo nor endo attacks occur due to the steric requirement of the transition state.

The addition of CSI to 1,3-dienes has been extensively studied (14-19). After some initial confusion, it is now clear that in every case studied the initial reaction product is a NCS- β -lactam. In some cases such as butadiene (16) the initial adduct 17 is not thermally stable but rearranges to 1,4 addition products 18 and 19 along with elimination product 20 presumably via dipolar intermediate 21 (19).

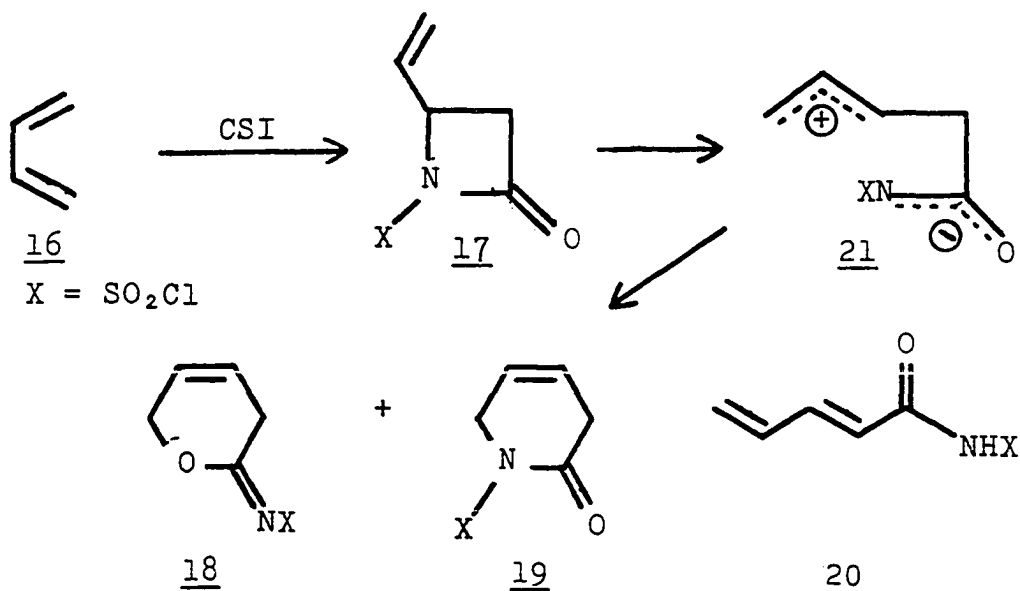

Initial β -lactam formation is in agreement with orbital selection rules predicting preference for CSI to undergo antarafacial attack. As a consequence, CSI cannot participate in concerted 1,4 additions except through the unlikely $\pi^4a + \pi^2a$ mode (8).

A concerted pathway is not necessarily in conflict with available kinetic data or observed addition orientation (20). Concerted cycloaddition reactions can be thought of as nonsynchronous, i.e., have different rates of bond formation which would be expected, to some extent, for highly polar molecules such as CSI. To the extent that there is charge separation in transition state 22 polar solvents will accelerate reaction rates and addition will occur in a mode which best stabilizes developing positive charge.

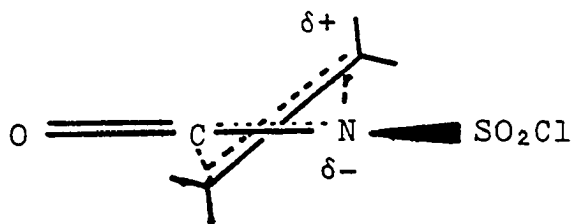
22

Despite Graf's claim that NCS-β-lactam and NCS-amide are formed simultaneously from the same intermediate there have been an increasing number of cases reported where non β-lactam products are formed from dipolar opening of thermally unstable NCS β-lactams.

Graf and Biener (21) reported the addition of CSI to camphene (23) which gave λ-lactam 24 and NCS-unsaturated amide 25a. They proposed direct formation of intermediate

26 which could either undergo Wagner-Meerwein rearrangement followed by ring closure to give 24 or proton transfer to form 25a.

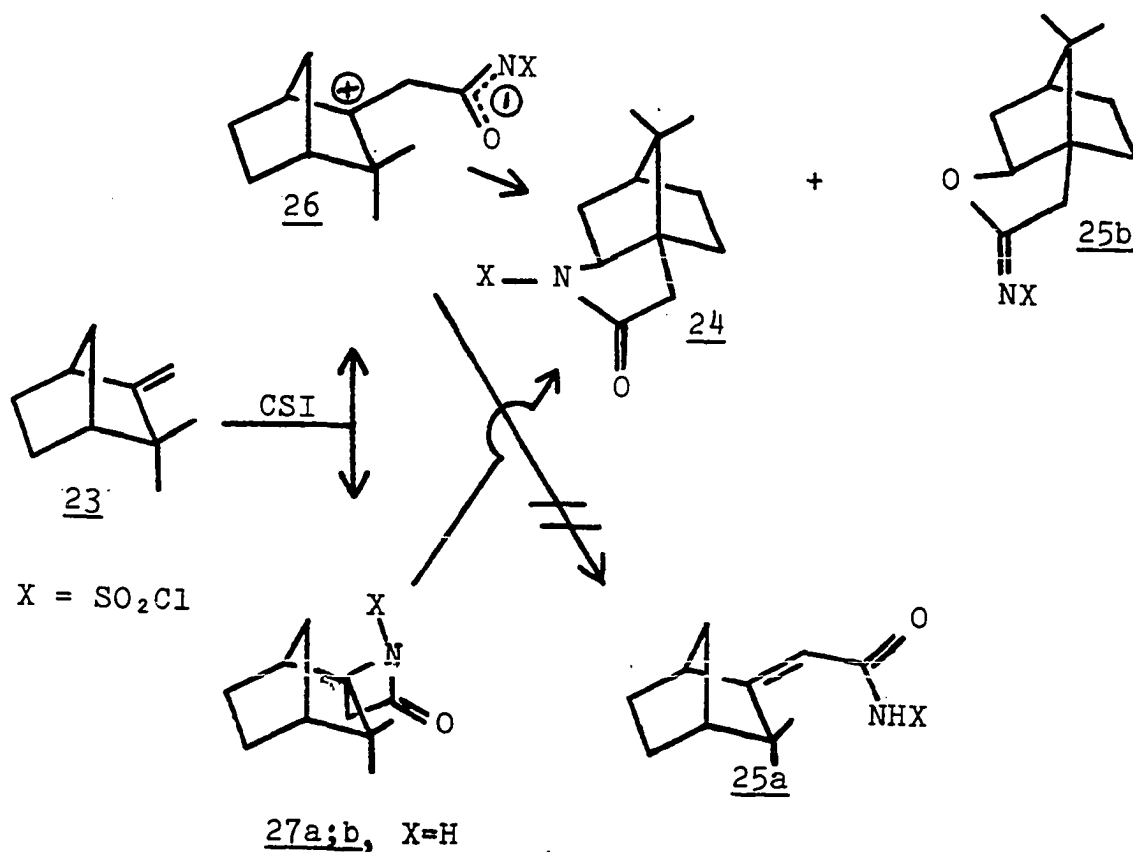

Clauss (2) later reported that 24 and 25a were formed from 27a which was observed by infrared at -50° . Malpass confirmed Clauss' ir observation by low temperature reduction of 27a which gave 27b. Malpass and Tweddle (22) also assigned structure 25b instead of 25a for the higher melting product.

In this work Malpass and Tweddle also reported that the ratio of 24 to 25b was solvent dependent. The ratio varied from 3:1 in hexane to 1:6.7 in nitromethane. This conflicts with previous statements that product ratios were solvent independent for CSI/olefin reactions (4).

Clauss (2) reported observation and trapping of NCS- β -lactam (28) at -30° when CSI was added to α -methyl styrene (29).

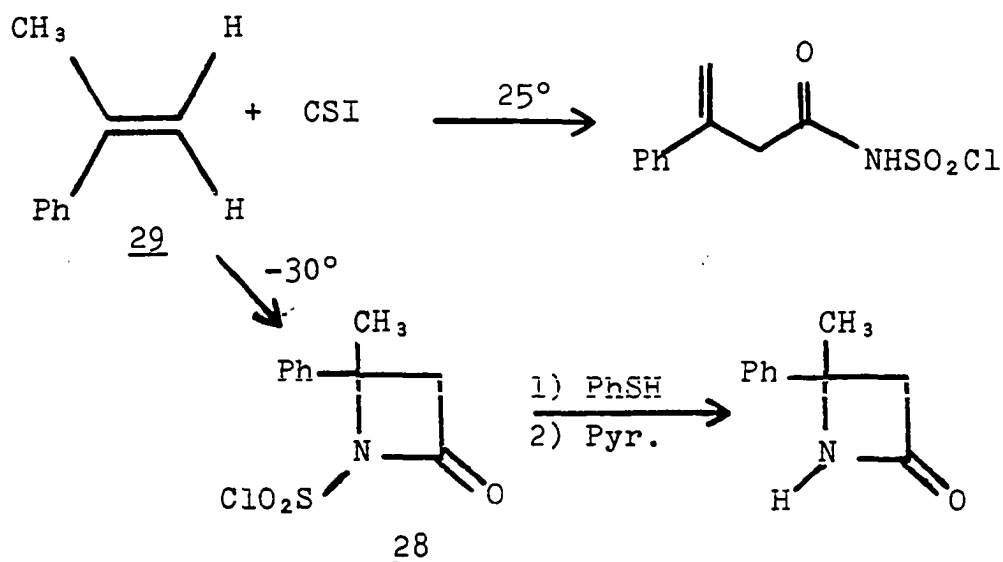

Doyle and Conway (23) reported reaction of CSI with 2,2-tetramethylene-1,2,3,4-tetrahydronaphthalene (30). Iminolactone 31, the only isolable product, was the first example of a CSI addition which demonstrated ring closure through oxygen.

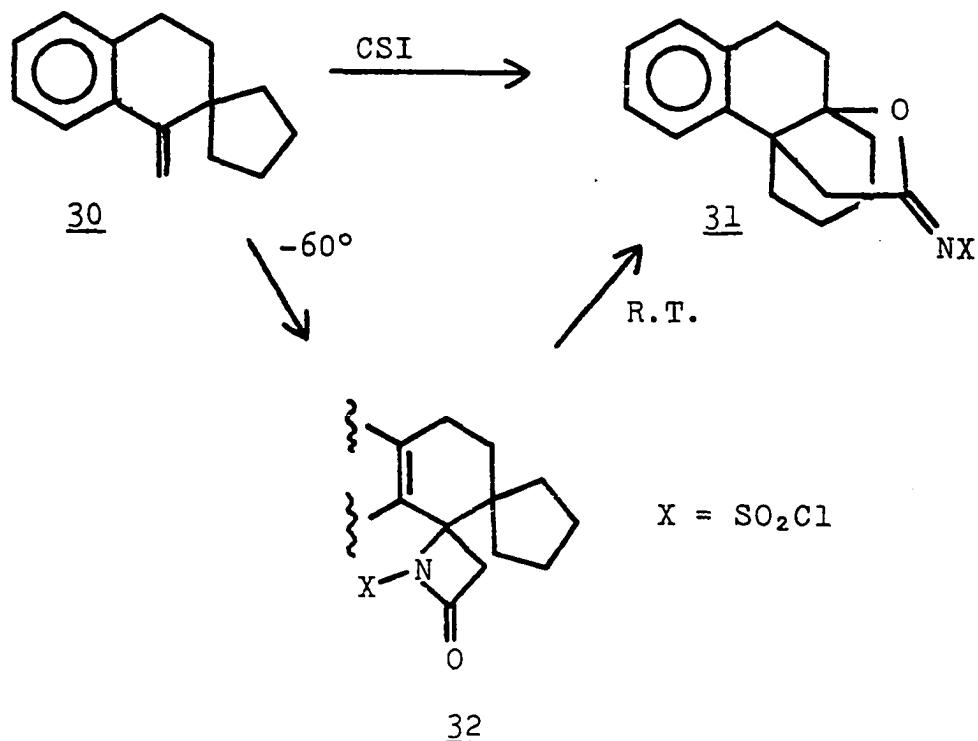

NCS- β -lactam 32 was postulated as a first formed intermediate based upon nmr evidence at -60° . When warmed to room temperature only the nmr spectrum of 31 could be observed.

Paquette *et al.* (24,25) reported the addition of CSI to bullvalene (33) at 0° which gave 34b-37b as products after thiophenol-pyridine reduction. Significantly, the yield of β -lactam 34b 35b fell to 2% when the reaction was

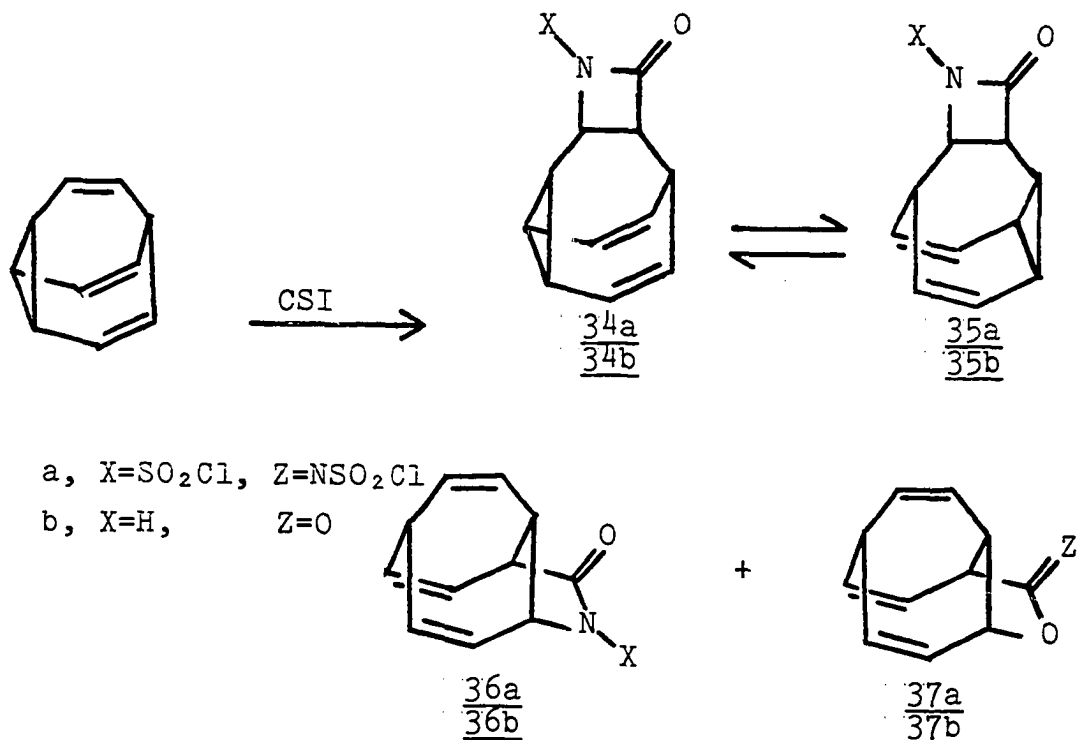

warmed to 40° prior to workup. Nmr and ir studies established that initially 34a 35a was formed faster than 36a or 37a. Ultimately, the concentrations of 36a and 37a increased at the expense of 34a 35a. A reasonable interpretation of these results would be an initial concerted reaction to form 34a 35a which then rearrange via a dipolar intermediate to the more stable 36a and 37a.

A previously mentioned example of thermal rearrangement of first formed NCS- β -lactams is the CSI-diene work of Moriconi and Meyer (19). Also, Malpass and Twedde (26) studied

the reaction of CSI with cyclic dienes. He observed the expected prior formation of NCS- β -lactam which led ultimately to rearrangement products. Of particular significance was the addition of CSI to bicyclooctadiene 38. NCS- β -lactam 39a,

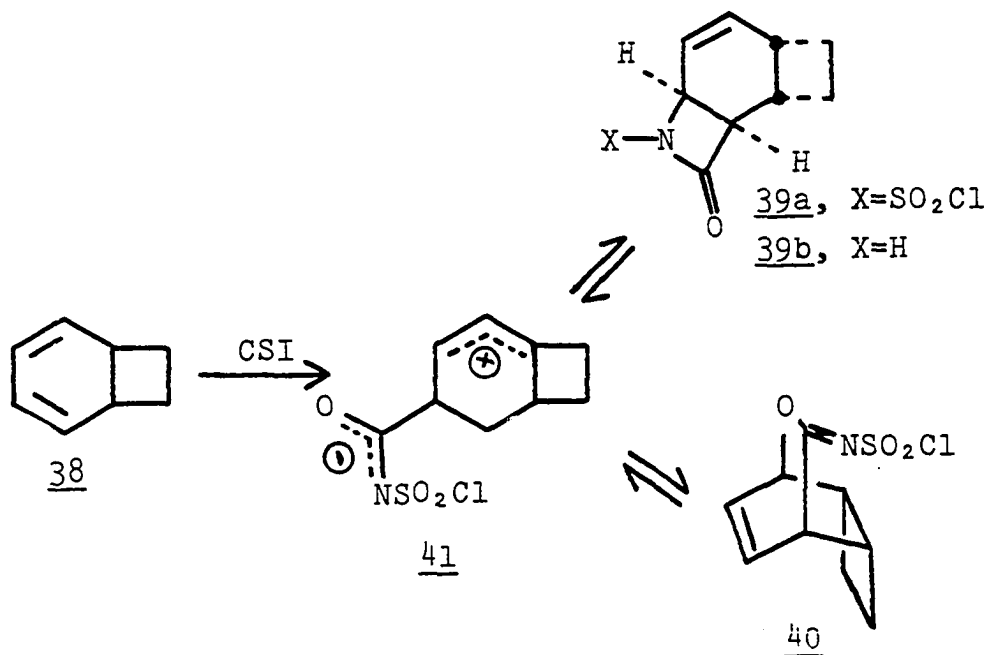

the initial reaction product, could either be observed spectroscopically or reduced at low temperature to give 39b. Iminolactone 40 could be isolated pure after a greater reaction period. When 40 was redissolved, ir bands attributed to 39a were observed developing after 1 hour. If one assumes that 41 is an intermediate in the conversion of 40 to 39a (a reasonable assumption) then this is the most conclusive evidence to date for formation of a NCS- β -lactam from a dipolar intermediate.

Moriconi *et al.* (27) reported the addition of CSI to cycloheptatriene (42) gave iminolactone 43 in high yield.

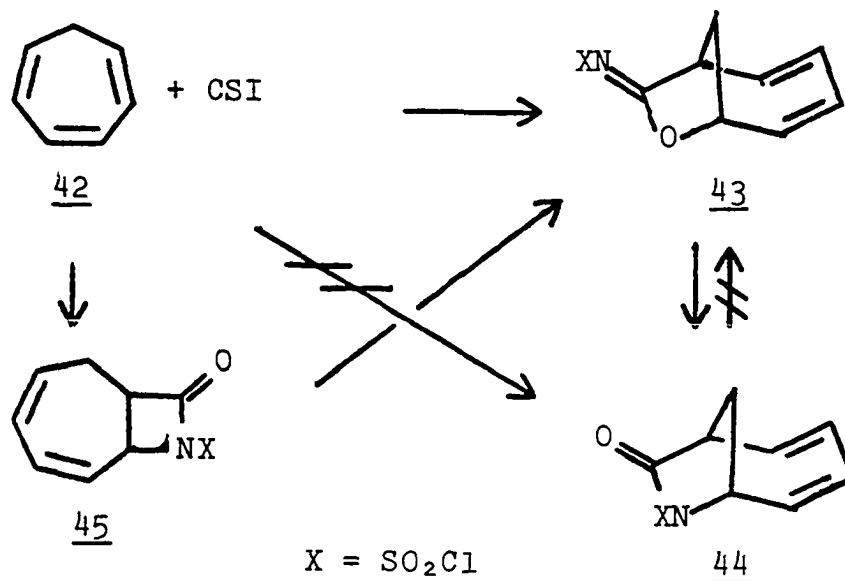

They proposed initial $\pi^6s + \pi^2a$ cycloaddition to form lactam 44 which could then rearrange to iminolactone 43.

Careful reinvestigation of this reaction by Malpass (28) ruled out this proposal. He reported that: β -lactam 45 was present in low concentration initially, iminolactone 43 was the first major product and the lactam 44 was not an initial product but was formed slowly at the expense of 43.

CSI has been used successfully to generate and trap a number of interesting carbonium ions. Paquette *et al.* (29, 30) and subsequently Wegener (31) reported the generation

of homotropylium cation 46 by reaction of CSI and cyclo-octatetraene (47). Internal trapping of dipolar ion 46 resulted in formation of bicyclic lactam 48.

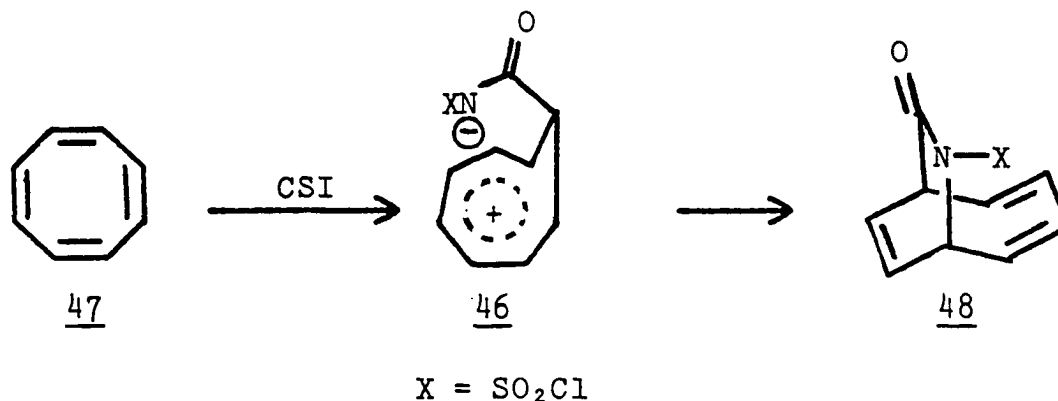

Paquette (32,33) generated the bicyclo[3.1.0]hexenyl cation 49 by the addition of CSI to hexamethyldewarbenzene (50) as evidenced by formation of tricyclic lactam 51.

Intervention of bicyclo[3.1.0]hexenyl cations in electrophilic additions to hexamethyldewarbenzene might have otherwise been undetected since "biparticulate" electrophiles result in products of general type 52 (34).

Paquette *et al.* (35) have postulated 1,3-bishomotropilium ion 53 as an intermediate in the reaction of CSI with *cis*-bicyclo[6.1.0]nonatriene 54 gave *trans*-lactam 55 as the ultimate product (see p. 56).

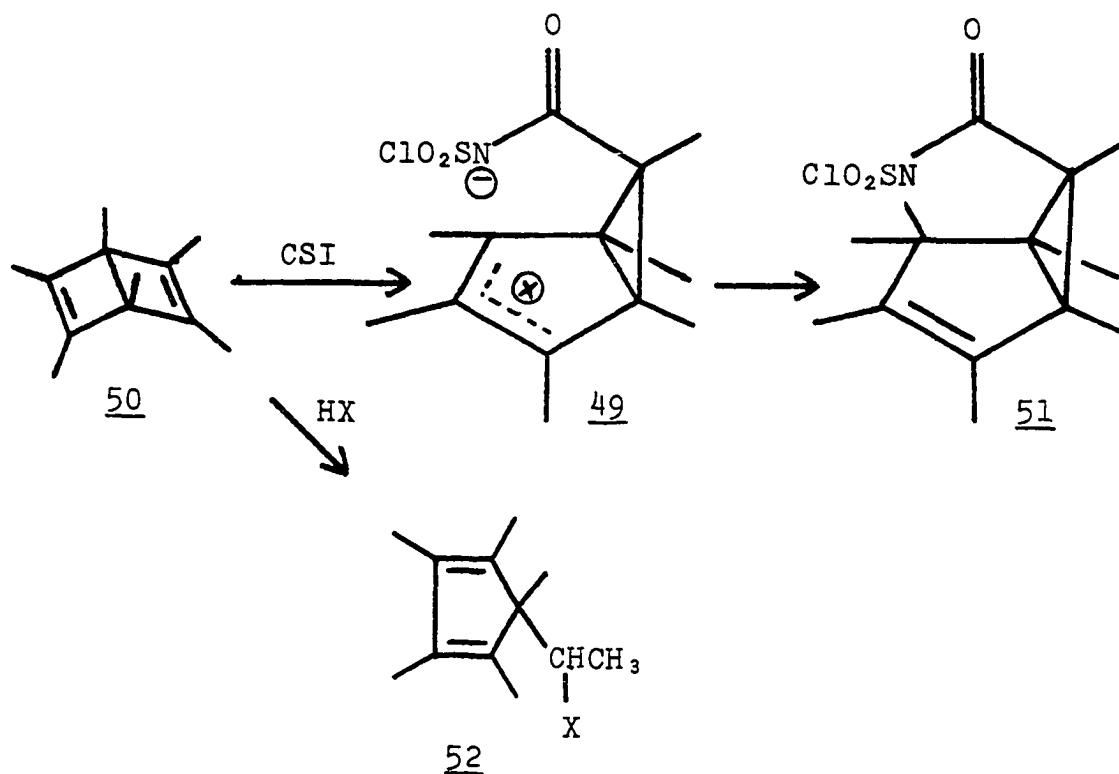

In the case of 47, ir studies were conducted which showed complete absence of an NCS- β -lactam intermediate. However, it would be surprising that if an NCS- β -lactam intermediate were involved it would accumulate in observable concentration due to the elevated temperature (75-80°) necessary for reaction.

Paquette did not report any experiments which might have detected an NCS- β -lactam intermediate in the addition of CSI to hexamethyldewarbenzene 50 (32,33).

RESULTS AND DISCUSSION

The purpose of this investigation was to study the olefin addition chemistry of chlorosulfonyl isocyanate. It was hoped that careful selection of reactants would lead to interesting and novel products, contribute to further understanding of the reaction mechanism and extend the synthetic utility of CSI.

Investigation of CSI additions to cyclopropenes was deemed an important objective for the following reasons. Attempts to trap cyclopropyl cations by solvolysis of cyclopropyl tosylates had led to isolation of products derived from allylic carbonium ions (36). To accommodate these results Depuy (36) postulated that the cyclopropyl cation is not an intermediate in these solvolyses but that ring opening occurs simultaneously with loss of tosylate to give directly the allyl cation.

Pettit (37) reported that diazotization of cyclopropyl amine hydrochloride (56) gave unrearranged chloride 57.

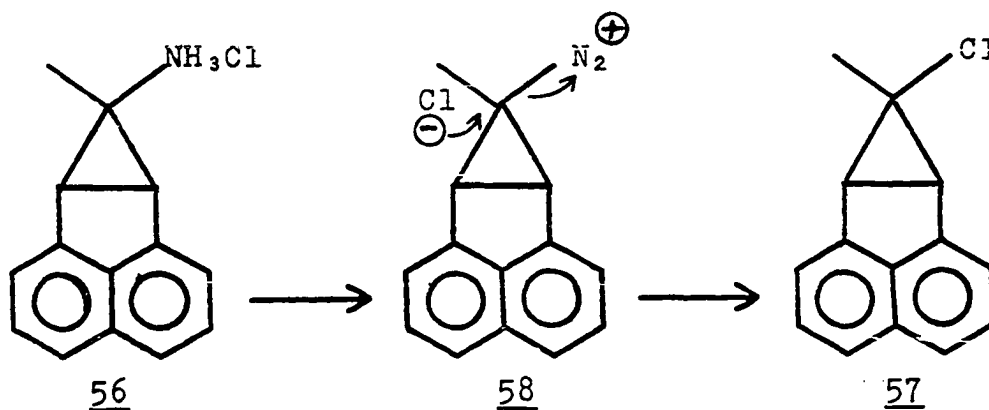

This is one of the few reactions where the cyclopropyl ring fails to open under cationic conditions. However, Pettit believed the reaction did not involve a carbonium ion intermediate but proceeded through diazonium chloride ion pair 58 via an $S_{\text{N}}1$ mechanism.

If cyclopropyl carbonium ions do have a finite existence the addition of CSI to cyclopropenes might generate and trap them before rearrangement occurs. In the past CSI has been successful in trapping carbonium ions that otherwise rearrange before trapping can occur (24,25,29,30,32,33). This is due to the fact that CSI is a "uniparticulate electrophile" (38), *i.e.*, has both positive and negative centers in the same molecule.

Equally important, successful trapping would lead to bicyclic lactam 59 which when treated by standard methods might give strained azabicyclo[2.1.0]pentene 60.

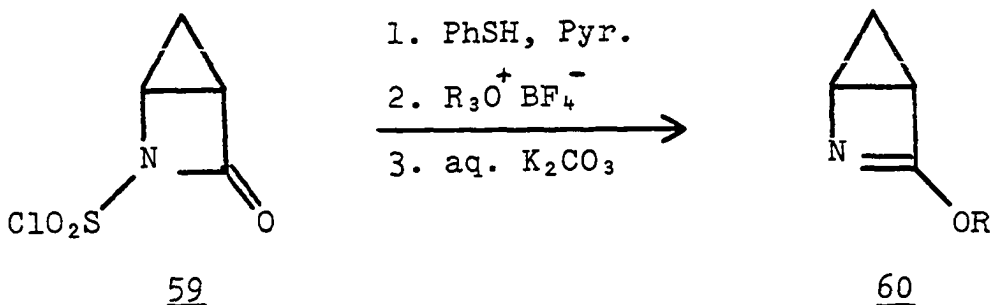

Due to its synthetic availability and high relative stability 1,3,3-trimethylcyclopropene (61) was chosen for reaction with CSI. Reaction of CSI with 1,3,3-trimethylcyclopropene gave an unstable white solid.

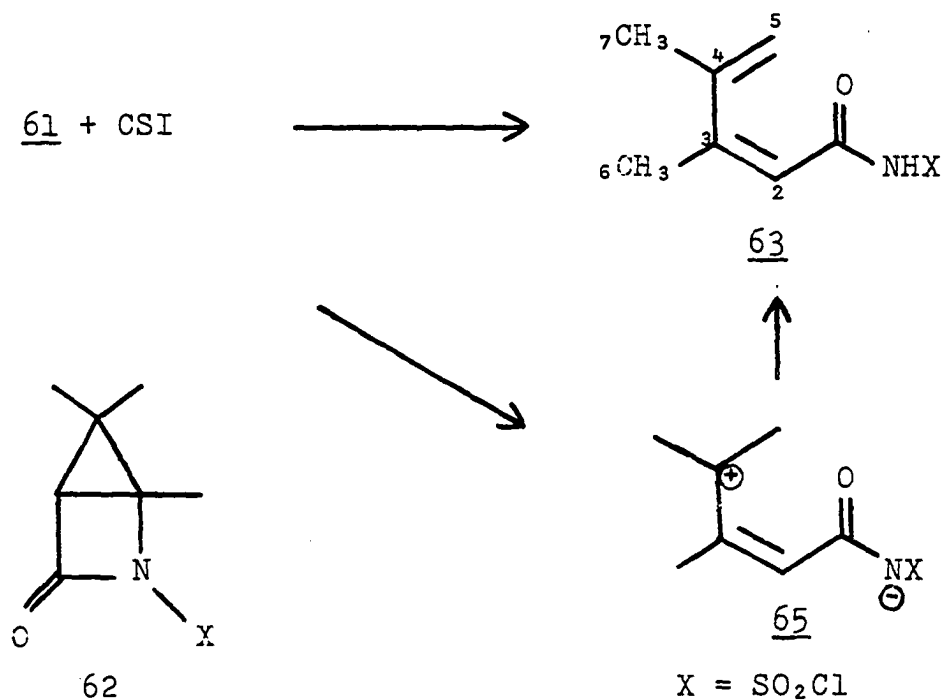

Although this solid was not stable enough to give an acceptable elemental analysis, its low and high resolution mass spectra clearly indicated that mono-addition of CSI had occurred. Infrared bands at 3390 (N-H) and 1678 cm⁻¹ (C=O) indicated that the product was not NCS- β -lactam 62 (ca. 1820 cm⁻¹ expected) but instead NCS-dieneamide 63. The nmr spectrum agrees well for structure 63. Comparison of its nmr spectrum with that of diene amide 64 (19)

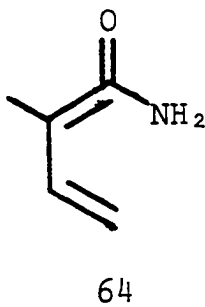

confirms the following assignments: δ 9.05 (N-H), 6.06 (S, H-2), 5.67 and 5.39 (H-5), 2.40 (S, H-6), 1.97 ppm (S, H-7).

The pathway leading to 63 most rationally involves formation of dipolar intermediate 65 which gives 63 after proton transfer. If a cyclopropyl carbonium ion was involved, CSI was not able to trap it under the experimental conditions employed.

Since it is known that alkyl substitution in the 2-position causes accelerated ring opening in the solvolysis of cyclopropyl tosylates (36), the reaction of less substituted cyclopropenes with CSI was judged more likely to give NCS- β -lactam products.

Reaction of CSI with cyclopropene resulted in the formation of uncharacterizable tars. However, addition of 1-methylcyclopropene to a solution of CSI in ether led to

isolation of a highly crystalline white solid. It was evident from mass spectral data and chemical analysis that 1-methylcyclopropene had added two molecules of CSI.

The nmr spectrum (100 MHz, 100 Hz sweep width, CDCl_3) of this solid exhibited the following absorptions: δ 1.90 (d of d, $J = 1.6, 0.8$ Hz, 3H), 5.18 (d, $J = 0.6$ Hz, 1H), 5.44 ppm (m, 2H). The δ 1.90 absorption collapsed to a doublet ($J = 0.8$ Hz) when irradiated at 542 Hz. Irradiation at 543.1 Hz caused collapse of this same multiplet to a singlet. Irradiation at 543.5 Hz resulted in collapse of the methine absorption 5.18 to a singlet. Irradiation throughout the methyl absorption caused no change in the methine peak. Structural unit 66 can be deduced from the chemical shifts and double irradiation experiments.

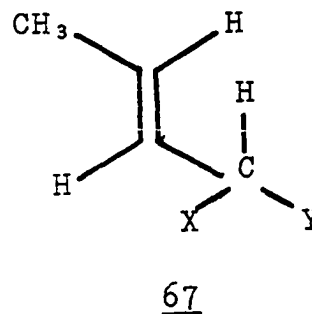
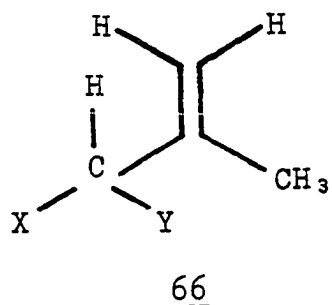

X, Y = electron withdrawing groups

Structural unit 67 is ruled out by the small magnitude of the observed coupling constants (39).

Three structures 68-70 can be drawn which are consistent with structural unit 67 and the chemical composition of the isolated product. Structure 68 was favored

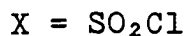
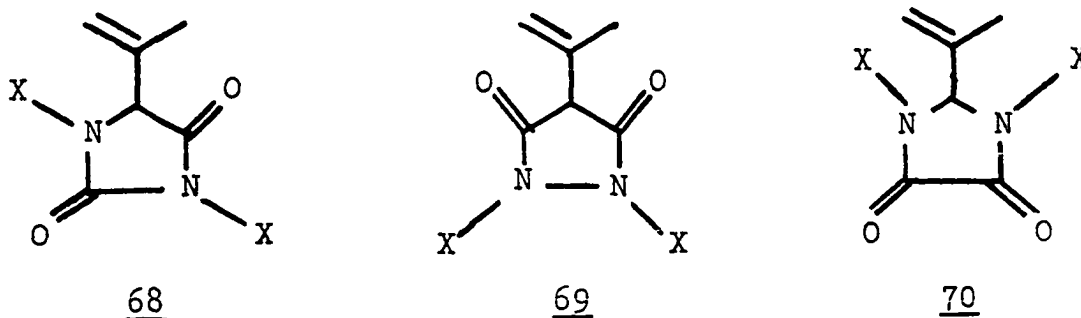

because of two different carbonyl absorptions (1760 and 1730 cm⁻¹) exhibited in the ir spectrum of the reaction product. Structures 69 and 70 would be expected to exhibit only one carbonyl absorption. Crystallographic structural determination confirmed assignment of structure 68 for the isolated solid (40).

Formation of 68 can be rationally explained by initial attack of CSI generating dipolar intermediate 71 which is itself trapped by CSI.

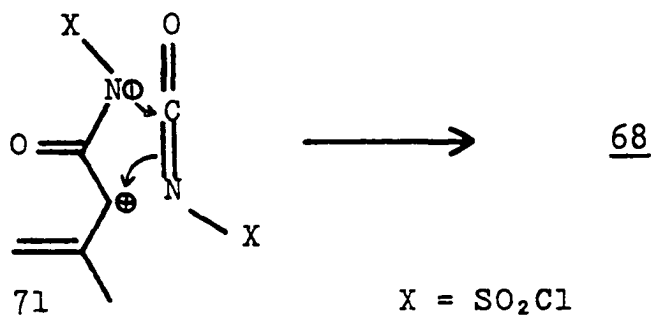

In an effort to isolate a 1:1 adduct, inverse addition (adding CSI to a solution of 1-methylcyclopropene) was carried out. Again, 68 was the only isolable product.

After conclusion of this work Köster et al. (41) reported that Fisher and Applequist's (42) original synthesis of 1-methylcyclopropene was incorrect. Under their conditions some 1-methylcyclopropene is produced but the major reaction product is methylene cyclopropane. Needless to say, the 1-methylcyclopropene used in the above experiments was prepared by Applequist's procedure.

Fortunately, methylene cyclopropane reacts only very slowly with CSI at room temperature. At 0° there was essentially no reaction of CSI with methylenecyclopropane.

Although the presence of methylenecyclopropane had no effect on the original addition, it was clear that CSI was still in excess during the inverse addition.

In a further effort to isolate a 1:1 adduct pure 1-methylcyclopropene prepared by Köster's procedure, was again reacted with CSI using inverse addition. The only isolable product was still bis-adduct 68.

Many advances concerning the mechanism of CSI additions to olefins had occurred since the commencement of this study. In particular it was now clear that in many cases initially formed, thermally labile NCS- β -lactams were

involved along reaction pathways which led ultimately to rearrangement products (see Introduction).

These results pointed to the possibility that NCS- β -lactam 72 might precede formation of dipolar intermediate 71 but was simply not detected under the conditions employed.

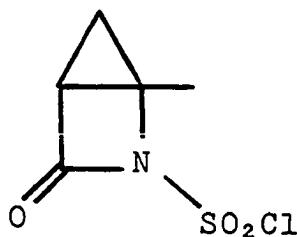

72

In order to investigate this question, a low temperature nmr experiment was undertaken (Table 1). From these experimental results, it can be concluded that 72 was not present in observable concentrations. Low temperature reduction also proved unsuccessful in trapping 72.

From these experiments NCS- β -lactams cannot be excluded as intermediates in the addition of CSI to cyclopropenes. The possibility still exists that they are intermediates which are too unstable to accumulate in observable concentrations. This is unlikely, however, due to the following argument. From what is known about cyclopropyl tosylate solvolyses rupture of the C₂-C₃ bond is concomitant with positive charge build up at C-1. Furthermore, closure

Table 1. Low temperature nmr spectra of the CSI-1-methylcyclopropene reaction in dimethyl ether

Chemical Shifts	6.33 ^a	5.33	5.26	4.39	4.25	2.10 ^a	2.00	1.86 ^a	0.88
Multiplicity	M	S	M	S	S	M	S	S	D
Integration 1 ^b	5.0	8.0	5.5	2.0	2.0	15.0	2.0	11.5	10
Integration 2 ^c	3.0	7.5	2.0	1.8	1.8	10.0	2.5	9.0	6.0
Integration 3 ^d	3.0	8.0	2.0	0.0	2.0	9.0	2.0	11.0	5.5

^aAbsorption due to 1-methylcyclopropene.

^bImmediately after introduction into the probe at -60°.

^cTaken after temperature stabilized at -30° after warming from -60°.

^dSample taken from the probe and held at room temperature for 15 min. before introduction into the probe at -30°.

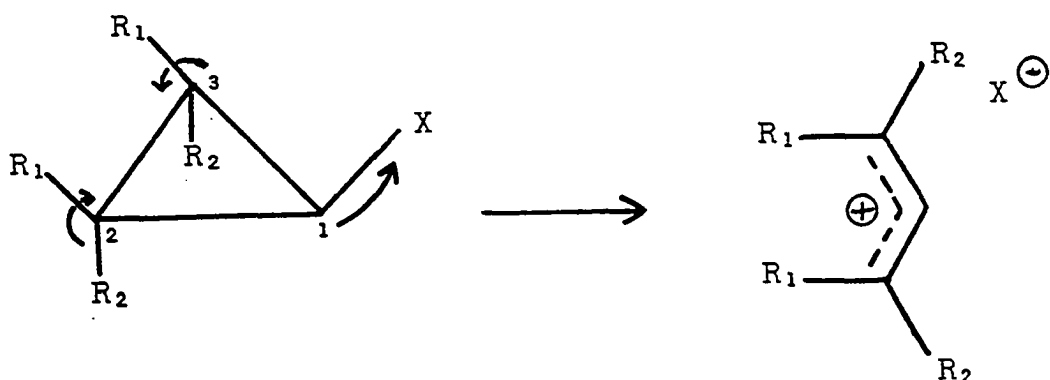

of an allyl cation to a cyclopropyl cation has never been demonstrated, i.e., the process can be considered irreversible. Thus, if NCS- β -lactams are intermediates they must be formed by a concerted process.

If CSI-olefin additions are concerted processes, they must occur in a nonsynchronous (see Conclusions) manner. Figure 1 depicts the allowed $\pi^2S + \pi^2A$ pathway.

At some point during this cycloaddition positive charge begins building up at C_1 . At this same instant the C_2-C_3 bond must begin breaking in an irreversible manner. As this hypothetical addition continues it must lead inevitably to products derived from dipolar intermediates.

Reaction of CSI with heterocyclopentadienes was envisioned as a facile route to heterocycloheptatrienes. Since CSI is known to react with dienes to give initial β -lactam products (19) it was reasonable to expect that addition of CSI to various heterocyclopentadienes would

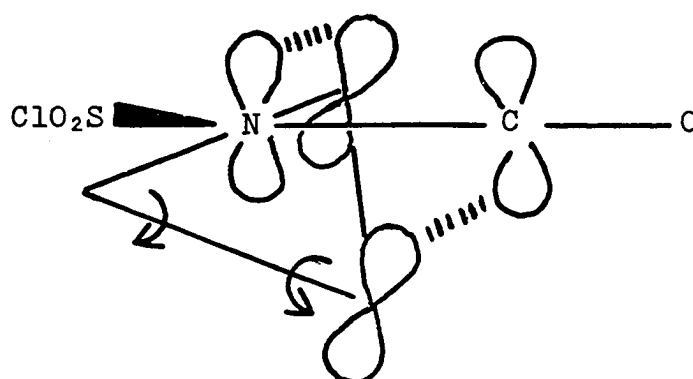
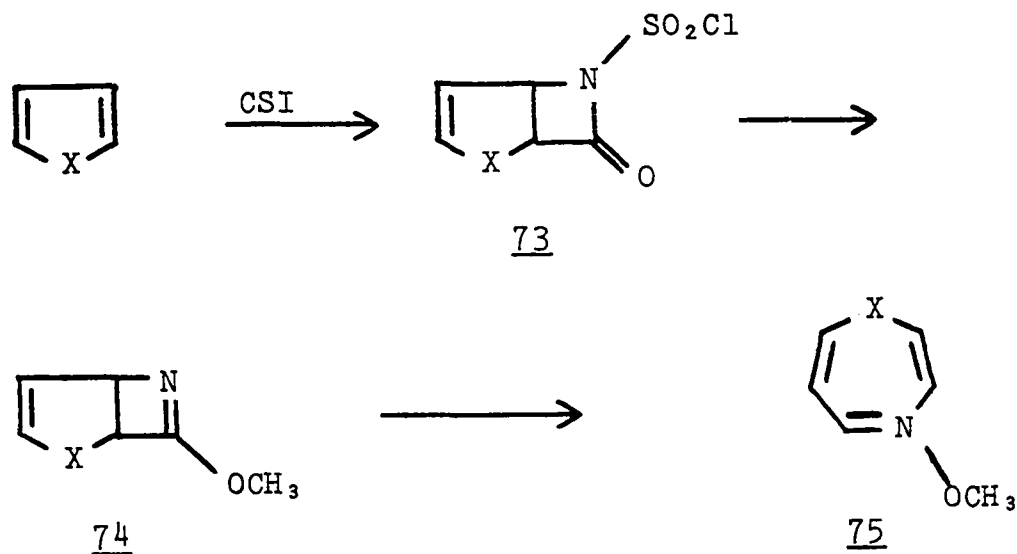
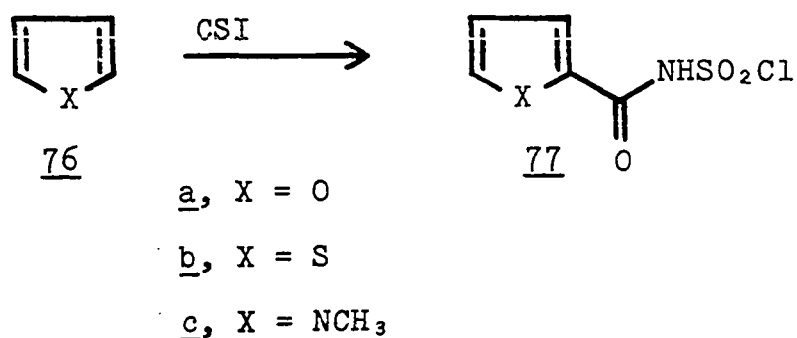

Figure 1. Initial transition state for the reaction of ClO₂S and cyclopropenes.

lead to NCS- β -lactams 73. NCS- β -lactams 73 might lead to imino ether 74 when reduced and treated with Meerwin's reagent. Either thermolysis or photolysis of 74 could result in ring cleavage with formation of 75.



Graf (43) reported reaction of furan (76a) with CS_2 which gave 77a as the only product in high yield. Similarly thiophene (76b) gave 77b when reacted with CS_2 . These results were verified by the author.



For completeness, the remaining member of the aromatic heterocyclopentadienes series, 1-methylpyrrole (76c) was reacted with CSI. The only isolable product was 1-methyl-2-NCS-carboxamidopyrrole 77c. The nmr and ir spectra were consistent with the assigned structure. Base hydrolysis of 77c gave 1-methyl-2-carboxamidopyrrole (78) in 34% yield. Amide 78 was converted to the known 1-methylpyrrole-2-carboxylic acid (79) (44) by treatment with refluxing 2N potassium hydroxide. Spectral data (nmr,ir) and agreement of its mp (133-4°) with the literature value (134-5°) constitute conclusive proof of 79.

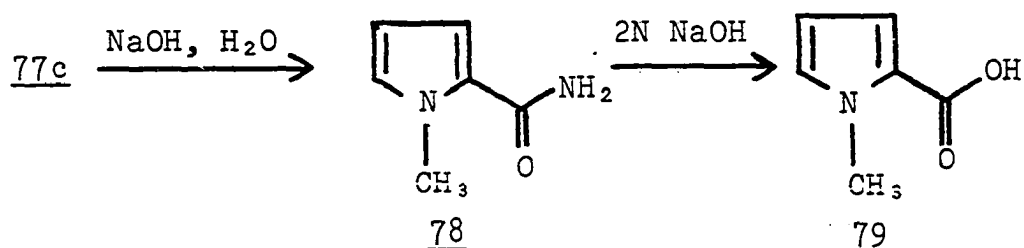

The reactions of 76a-c can be explained by direct formation of dipolar intermediates 80a-c which form products,

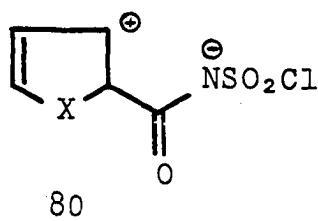

a, X = O

b, X = S

c, X = NCH₃

77a-c by either inter or intramolecular hydrogen transfer. The driving force for hydrogen transfer is rearomatization of the respective ring systems.

It was felt that prevention of hydrogen transfer would favor β -lactam formation. Ideally, reaction of the 2,5-dimethyl derivatives of furan 81a, thiophene 81b and 1-methylpyrrole 81c would lead to NCS- β -lactams 82a-c if CSI attacked the 2-position. Although 2,5-disubstituted furans

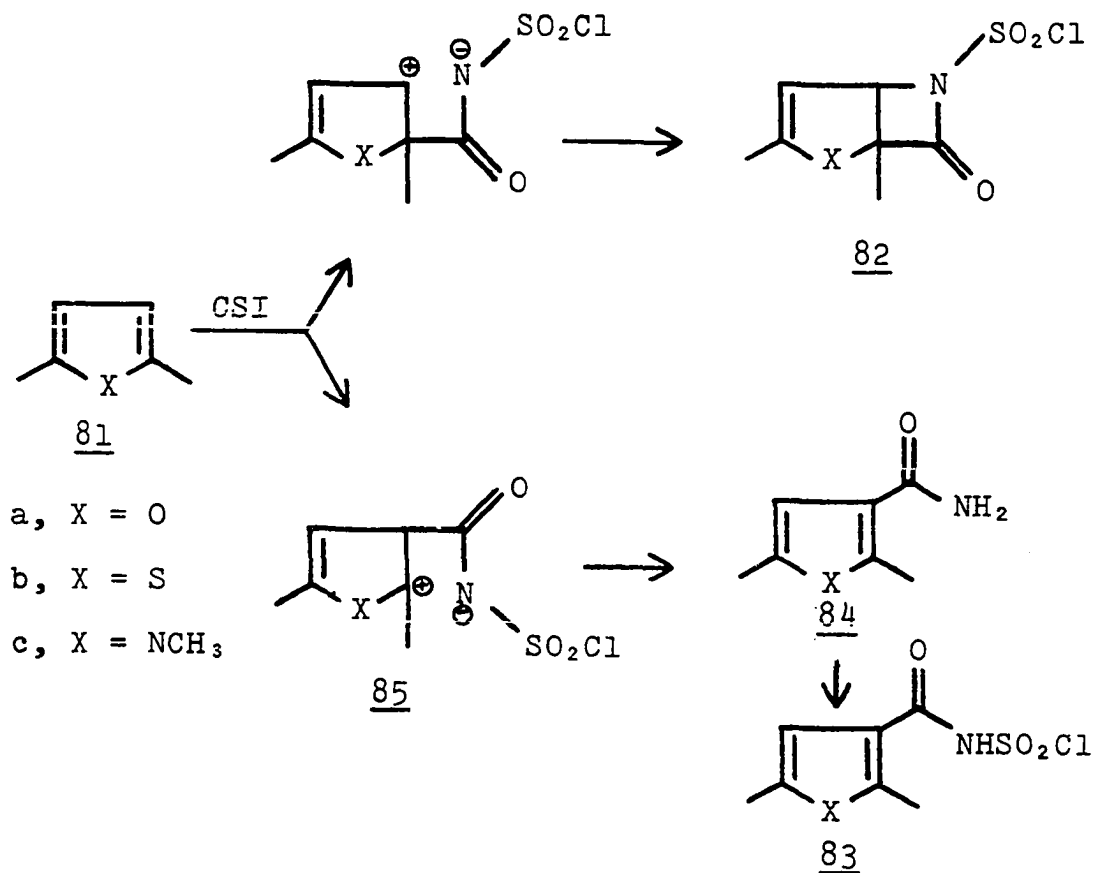

usually undergo electrophilic substitution at the 3-position, there is precedent for electrophilic attack at the 2-position. Oxidation of 2,5-diphenylfuran by nitric acid in acetic acid and ozonolysis proceed by initial attack of the electrophilic reagent at the 2-position (45).

Reaction of 81a with CSI gave NCS-amide 83a as the only isolable product. Spectral evidence (nmr,ir) was consistent with this structural assignment. Base hydrolysis of 83a gave known furamide 84a. Spectral data (nmr,ir) and agreement of its mp (125-7°) with the literature value (125°) (46) confirmed the structural assignment. NCS-amide 83a also gave 2,5-dimethyl-3-cyanofuran when treated with two equivalents of triethylamine.

Reaction of 1,2,5-trimethylpyrrole (81c) with CSI gave unstable NCS-amide 83c. Characterization of 83c proved difficult since it was unstable to standing at room temperature or dissolution in polar solvents. However, spectral evidence (nmr,ir) agree with the structural assignment. Base hydrolysis of 83c gave a small amount of 84c. Repetition of this base cleavage or attempted thiophenol-pyridine did not give characterizable amounts of 84c. Proposed structures 83c and 84c are consistent with the available data but are not rigorously proven.

Reaction of 2,5-dimethylthiophene (81b) with CSI proceeded very slowly under usual conditions. Nevertheless,

a small amount of NCS-amide 83b was isolated and characterized. When acetonitrile was employed as the solvent, complete reaction had occurred after 11 hrs. at room temperature. NCS-amide 83b was converted directly to known amide 84b.

Formation of 83a-c can be explained by attack of CSI at the 3-position which leads to formation of dipolar intermediates 85a-c. It was not clear whether attack was occurring exclusively at the 3-position or whether attack was also occurring at the 2-position but not leading to isolable products. Also, these experiments have not determined whether NCS- β -lactams are reaction intermediates.

It was deemed important to further explore these points. To this end the reaction of CSI and 81a was studied by infrared spectroscopy. The results of this investigation are shown in Table 2. A reasonable interpretation of this data is shown in Figure 2. Assignment of 82a to the higher of the two NCS- β -lactam bands is consistent with electron withdrawing oxygen being closer to the carbonyl in 82a than in 86. Assignment of 87 to the 1727 cm^{-1} band is consistent with the expected position of a NCS- γ -lactam. Also, furans are known to form 2,5-addition compounds as intermediates in electrophilic substitution reactions (45, p. 141).

The reaction of CSI with dimethyl furan was carried out at -10° in hope that unstable intermediates 82a, 86 and 87 would accumulate in isolable concentrations. At

Table 2. Infrared study of CSI and 2,5-dimethylfuran in diethyl ether at room temperature

Band Position	1830	1808	1769	1727 cm ⁻¹	
Time					
0.5 Hr	7	10	23	6	
0.8	8	13	18	13	
1.1	11	18	21	21	
1.4	12	23	27	34	band intensity
2.0	14	27	32	43	
7.0	16	29	38	50	
12.5	18	16	51	64	
overnight	17.5	11	51	67	
assignments	<u>82a</u>	<u>86</u>	<u>87</u>	<u>83a</u>	

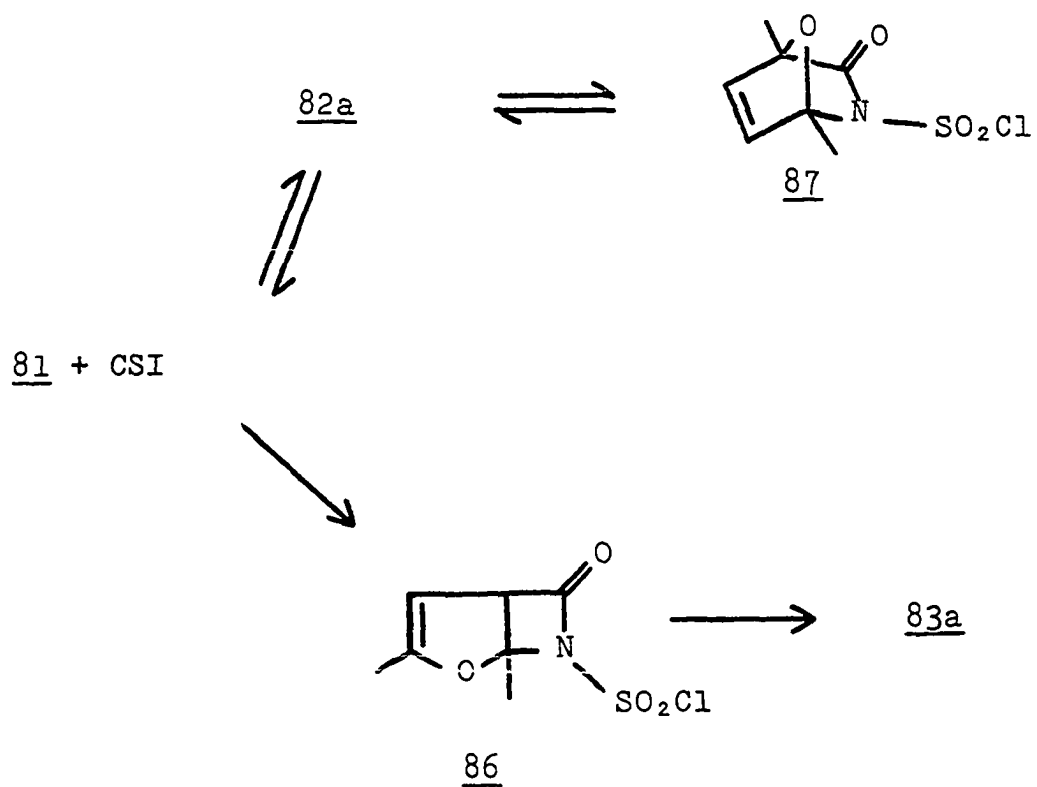
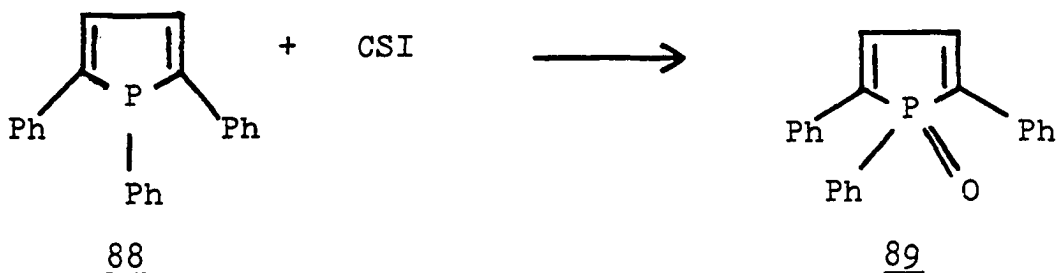

Figure 2. Interpretation of the infrared study of the reaction of SO_2Cl_2 and 2,5-dimethylfuran

completion of the reaction the only band observed was the 1727 cm^{-1} band. Apparently, attack occurs at both the 2 and 3 positions. It is not known whether β -lactam intermediates 82a and 86 precede the formation of dipolar intermediates.

The less aromatic 1,2,5-triphenyl phosphole (88) was reacted with CSI. The only isolable product was phosphine oxide 89. Apparently, the tendency of trivalent phosphorous to abstract oxygen obscures the CSI chemistry of 88. Next,



the reaction of CSI with 1,1-dimethyl-2,5-diphenylsilole (90) was studied. The reaction went smoothly in ether to give a bright yellow solid which proved to be a 1:1 adduct (chemical analysis). The solid was stable indefinitely in the absence of moisture but decomposed with loss of color in the presence of moisture or hydroxylic solvents to an uncharacterized product(s). The initial product might have structure 91, 92 or 93 based upon the CSI chemistry of dienes. Products 94 and 95 might also be expected since electron donation from the phenyl group might reverse the

normal orientation of CSI-diene additions.

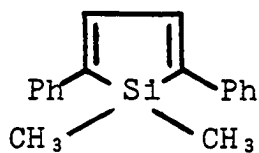

90

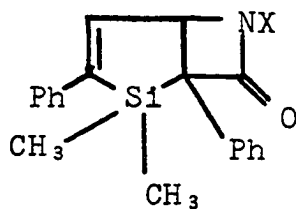

91

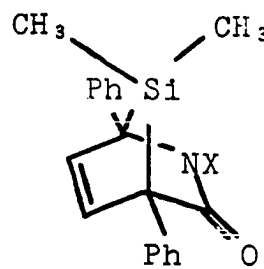

92

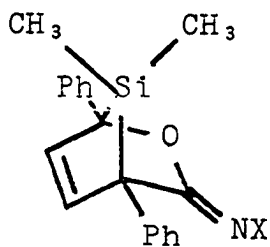

93

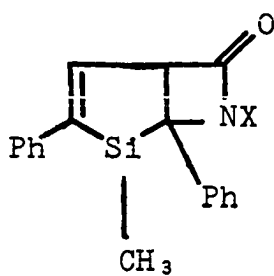

94

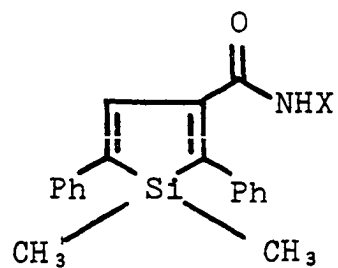

95

X = SO₂Cl

Since the ir spectrum of the 1:1 adduct exhibits no intense band in the carbonyl region, structures 91, 92, 94 and 95 need not be considered further. The nmr spectrum: (CDCl₃) δ 7.50-7.01 (m, 12H), 0.65 ppm (s, 6H); might be consistent with structure 93 based upon the nmr spectra of 96, 97 and 98 (Table 3). Note the accidental equivalence of the chemically nonequivalent silicon methyl groups of 98. However, the olefinic protons of the product absorb at lower field (aromatic region) than might be expected based on the spectra of 96-98. The high coloration of the reaction product and the 1506 cm⁻¹ C=N band of the product are clearly not consistent with structure 93 (Table 4) but are indicative of extensive conjugation. Structure 103 is more consistent with the available evidence. The medium intensity ir bands of the reaction product at 1582 and 1541 cm⁻¹ are consistent with the dienyl structure unit of 103.

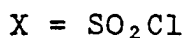
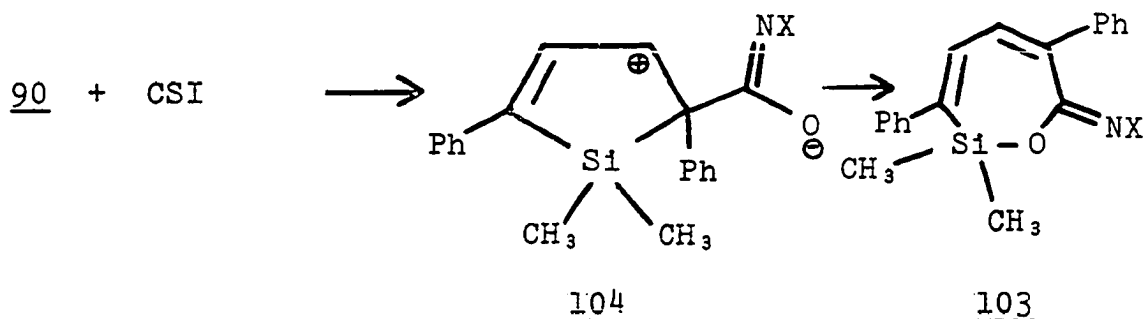

Table 3. Nmr chemical shifts (δ ppm) of related compounds

Compound	Olefinic H	Silicon methyl
<u>96</u> ^a	6.42	1.01, 0.49
<u>97</u> ^a	6.60	0.16, 0.10
<u>98</u> ^a	6.59	0.50, 0.50

969897^a(47).

Table 4. Infrared absorption bands (C=N) of selected compounds in cm^{-1} .

Compound	C=N	Phase
<u>99</u> ^a	1588	CH_2Cl_2
<u>43</u> ^b	1610	CCl_4
<u>31</u> ^c	1600	CHCl_3
<u>25</u> ^d	1606	CHCl_3
<u>100</u> ^e	1568	CHCl_3
<u>101</u> ^f	1527	KBr
<u>102</u> ^f	1545	KBr

99101100102X = SO_2Cl ^a(26).^b(28).^c(23).^d(22).^e(48).^f(19).

Collapse of dipolar intermediate 104 by attack of O^- on silicon would give 103.

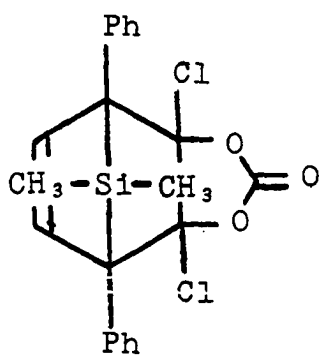
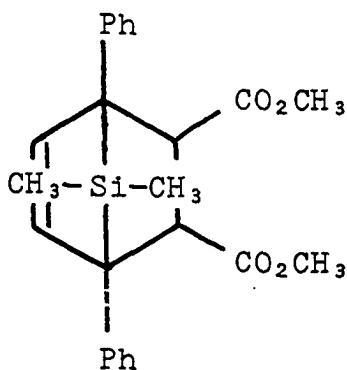
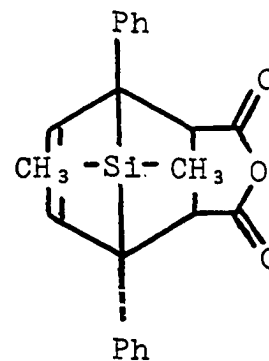
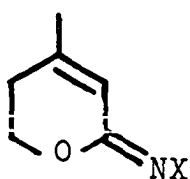
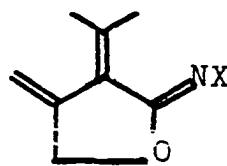
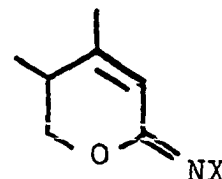
In order to establish precedence for CSI initiated migrations, reaction of CSI and trans- β -trimethylsilylstyrene (105) was studied. CSI reacted rapidly with 105 which resulted in formation of an unstable material. Attempted hydrolysis of suspected reaction product 106 did not give carboxysilane 107 but resulted in formation of trans-cinnamamide (108) (63%) and trans-cinnamitrile (109) (1%). Formation of 108 implicates NCS-amide 110 as the first formed hydrolysis product since reaction of CSI with styrene which was postulated to give 110 as a minor product gave 108 after treatment with water (43). Reaction of CSI with 105 gave 106 in 92% yield. Structural proof of 106 rests solely on nmr and ir evidence. Product 106 decomposed rapidly to give NCS-amide 110 when exposed to atmospheric moisture. The susceptibility of 106 toward hydroxylic compounds was further investigated. When generated in situ 106 reacted rapidly with β -phenethyl alcohol and quantitatively precipitated 110. Distillation of the filtrate gave trimethylphenethoxysilane 111. The structure of NCS-amide 110 is consistent with the spectral data and its hydrolysis to amide 108. The behavior of 105 toward CSI and the susceptibility of initial adduct 106 toward hydroxylic material lend further support for assignment of 103 as the CSI-silole 90 reaction product.

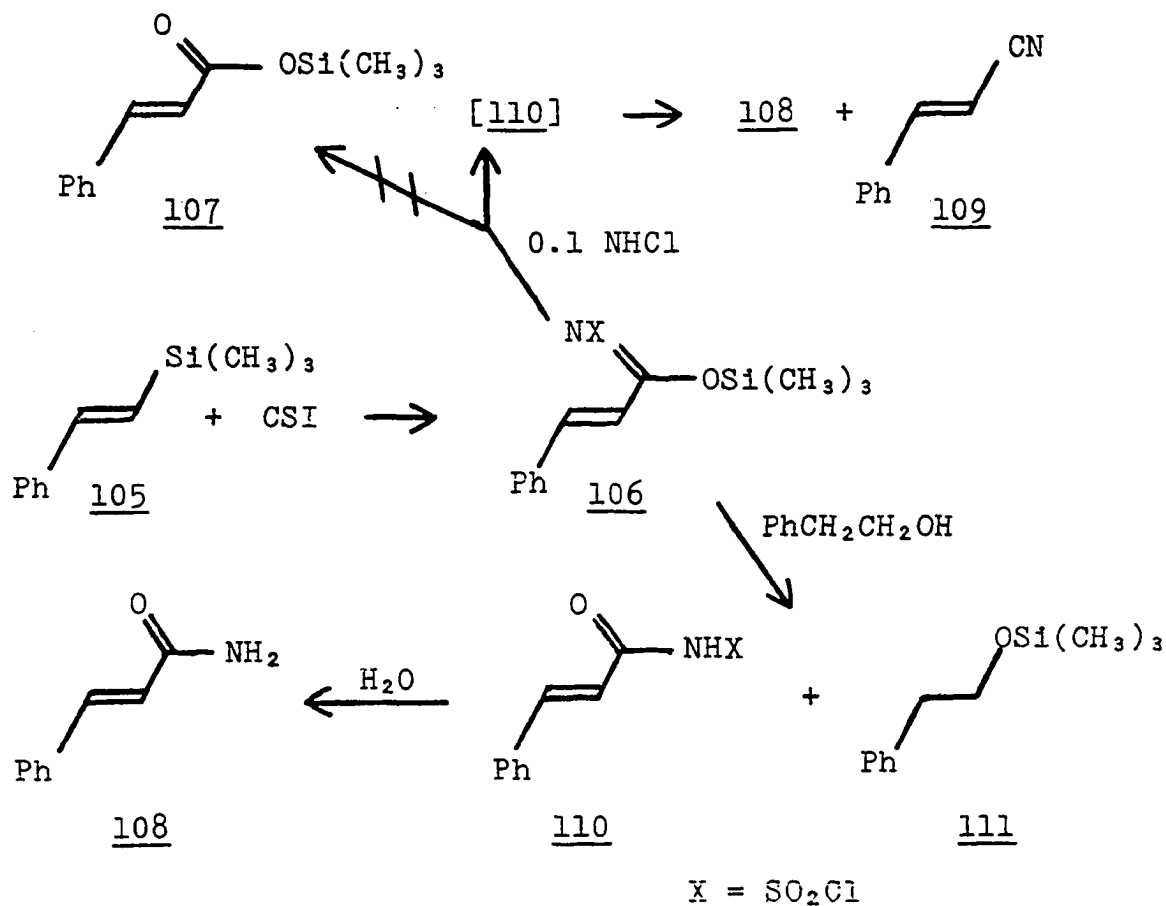

Since many olefins give NCS- β -lactams as the sole CSI reactions products, conversions of the type **105** to **108** may ultimately extend the utility of CSI in amide synthesis. Also, reagents of type **106** may prove useful as silylating reagents for sensitive alcohols (essentially neutral conditions) if this reaction proves to be general (when observed by nmr, formation of **111** was quantitative).

The relationship among cyclopropylcarbinyl, cyclobutyl and allylcarbinyl cations has occupied the interest of

organic chemists for over two decades (49,50). Because of this interest, generation of these ions by CSI additions was considered worthwhile. Cyclopropylcarbinyl cations could be generated by the addition of CSI to vinylcyclopropanes or methylenecyclopropanes. Addition of CSI to cyclobutenes or methylenecyclobutenes should generate cyclobutyl cations. Of particular interest was the possible involvement of NCS- β -lactam intermediates which might have preceded formation of these ions.

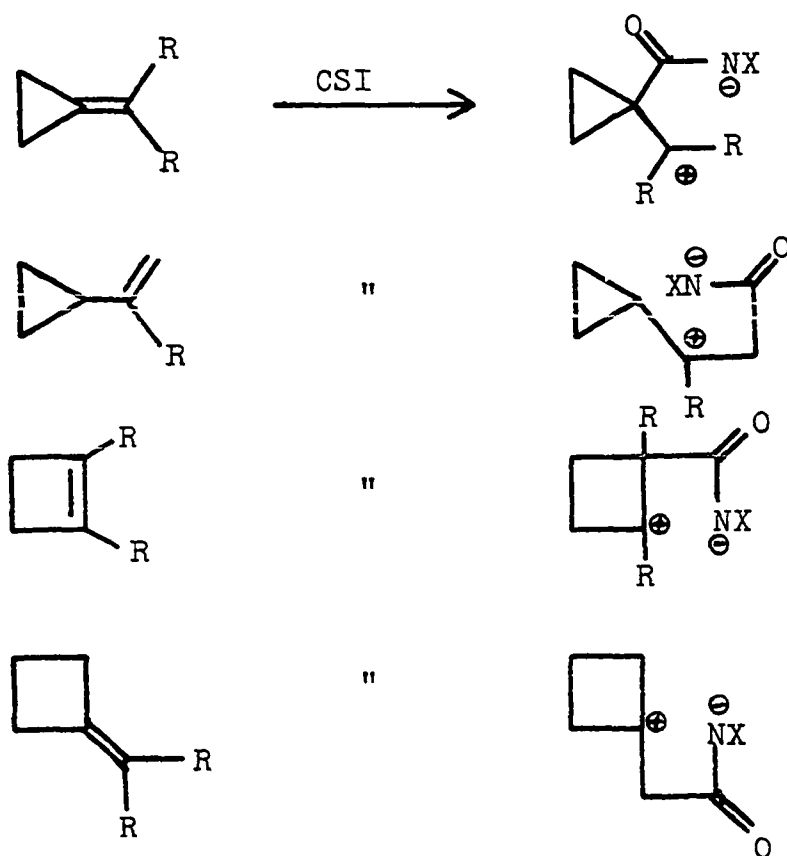

R = H, alkyl, aryl

X = SO₂Cl

At the time this work was undertaken CSI additions to cyclobutenes, methylenecyclobutanes or methylenecyclopropanes had not been previously investigated. Paquette had reported reaction of CSI with bullvalene (24,25) and bicyclo[3.1.0]hex-2-ene which gave only β -lactam 112 (51). The results of the bullvalene experiment were thought not to be applicable to vinylcyclopropanes in general. In the second case there was limited participation of the cyclopropyl ring since cyclopropylcarbinyl cation 113 cannot obtain the fully bisected geometry which is required for full stabilization (49, p. 1248; 50, p. 1315).

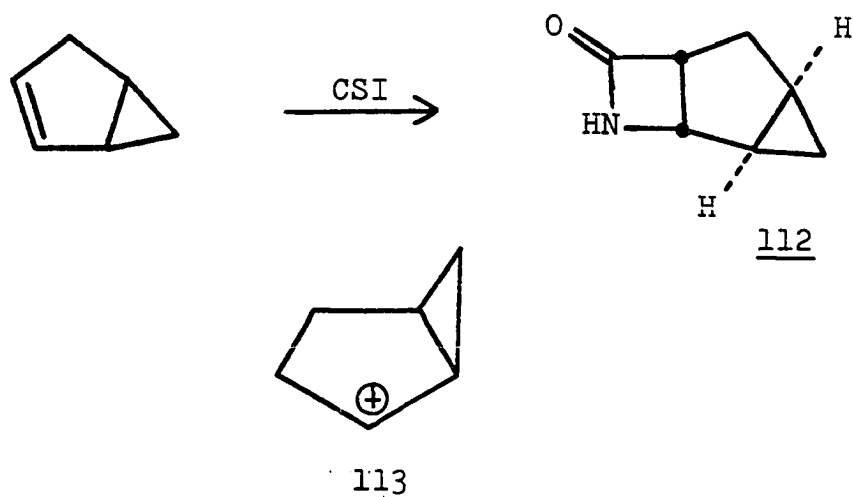

Reaction of CSI with 2-cyclopropylpropene (114) was undertaken. Before discussion of these results it is appropriate to consider what products are expected from dipolar intermediate 115 discounting any unusual effects

from the dipolar nature of this ion. Products derived from 116 or 117, formed from 115 by known rearrangements, would not be expected since tertiary cyclopropylcarbinyl cations are more stable than either secondary cyclobutyl or the corresponding allylcarbinyl cation and are not prone to rearrange (49, 50).

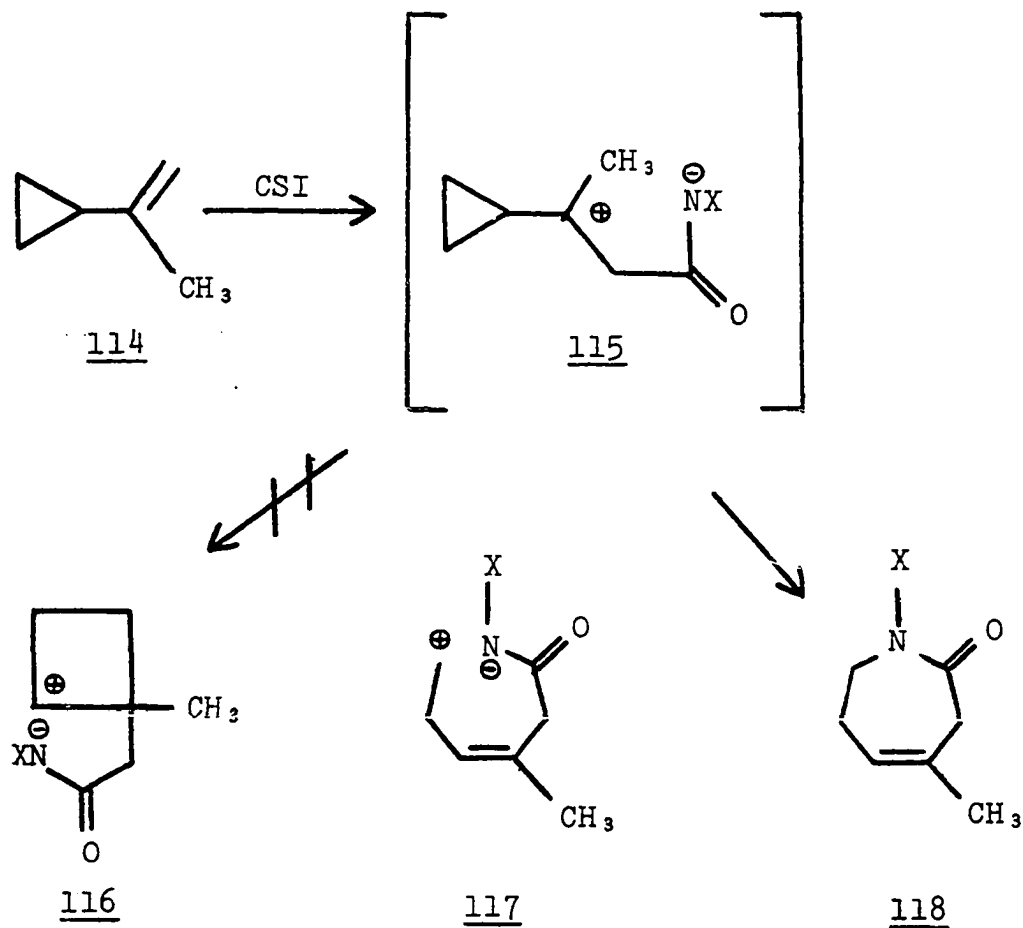

$\text{X} = \text{SO}_2\text{Cl}$

However, product 118 is expected since allylcarbonyl products can be formed from cyclopropylcarbonyl cations via two distinct pathways. The first pathway involving unimolecular type rearrangement to dipolar ion 117 and subsequent trapping is not predicted in this case. This pathway is generally favored by electron donating substituents at the beta cyclopropyl ring positions (49, p. 1238). The second pathway, a bimolecular type attack on an unrearranged cyclopropylcarbonyl cation 115, is favored by lack of β -substitution and would give rise to lactam 118 (49, p. 1238).

Reaction of CSI with 114 occurred rapidly and gave a mixture of amides 119a, 119b and 120 after typical water wash and thiophenol-pyridine workup. Amides 119a and 119b could be separated as a mixture by chromatography on Florisil¹ or as pure isomer 119b by repeated crystallization of the reaction mixture from hot benzene-hexane. Although the mass spectrum of 119b exhibits only very weak parent ions, observation of a metastable ion and m/e 97.0 which corresponds to formation of a daughter ion m/e 125 (base peak) from parent ion m/e 161 along with an acceptable chemical analysis confirm the proposed molecular formula. The ir spectrum indicated that 119b is an amide rather than a lactam by the

¹Trademark for Magnesiumtrisilicate.

presence of an amide II band (1595 cm^{-1}). The nmr spectrum and double irradiation experiment (Table 5) support structural assignment 119b.

The structure of 119a (not isolated pure) was deduced from the nmr of the isomeric mixture 119a and 119b: (CDCl_3) δ 6.10 (broad, 2H), 5.35 (hashed t, 1H), 3.57 (t, $J = 7\text{ Hz}$, 2H), 3.00 (s) and 2.94 (s, 2H), 2.52 (q, $J = 7\text{ Hz}$, 2H), 1.81 (d, $J = 1\text{ Hz}$) and 1.72 ppm (s, 3H). Isomer 119a has its H-6 triplet and H-5 quartet exactly coincidental with that of 119b. Distinct absorptions are observed for H-2 and H-7 in the two isomers.

Product 120 could not be separated from 119b. Its structural assignment is based upon subtraction of the nmr spectrum of 119b from the spectrum of a mixture of the two obtained from a chromatography fraction: nmr (CDCl_3) δ 5.70 (m, 1H), 1.99 (d, $J = 1\text{ Hz}$, 3H), 1.38 (m, 1H), 0.70 ppm (m, 4H). Amide 120 is most logically formed from reduction of NCS-amide 121.

Amides 119a and 119b are not expected products and have no precedent in CSI chemistry. Admixture of equimolar amounts of CSI and 114 in deuteriochloroform at -78° and warming to room temperature gave the following nmr: δ 10.11 (NH of 121 and 122, 14), 5.85 (m, H-2 of 121, 4), 4.98 (s, H-4 of 122, 18), 3.27 (s, H-2 of 122, 22), 1.98 (s, H-4 of 121, 10) and 1.7-0.4 ppm (cyclopropyl hydrogens of 121 and 122).

Table 5. Results from nmr irradiation experiments for 119b

Irradiating frequency	6.05 (NH ₂)	5.35 (H-4)	3.57 (H-6)	2.94 (H-2)	2.52 (-5)	1.72 (H-7)
-----	broad	t, $\underline{J} = 7.8$	t, $\underline{J} = 7.8$	s	q, $\underline{J} = 7.2$	s
312H	broad	-----	t, $\underline{J} = 7.8$	s	t, $\underline{J}7$	s
146H	broad	s	s	s	-----	s
206H	broad	t, $\underline{J} = 7.8$	-----	s	d, $\underline{J}7$	s

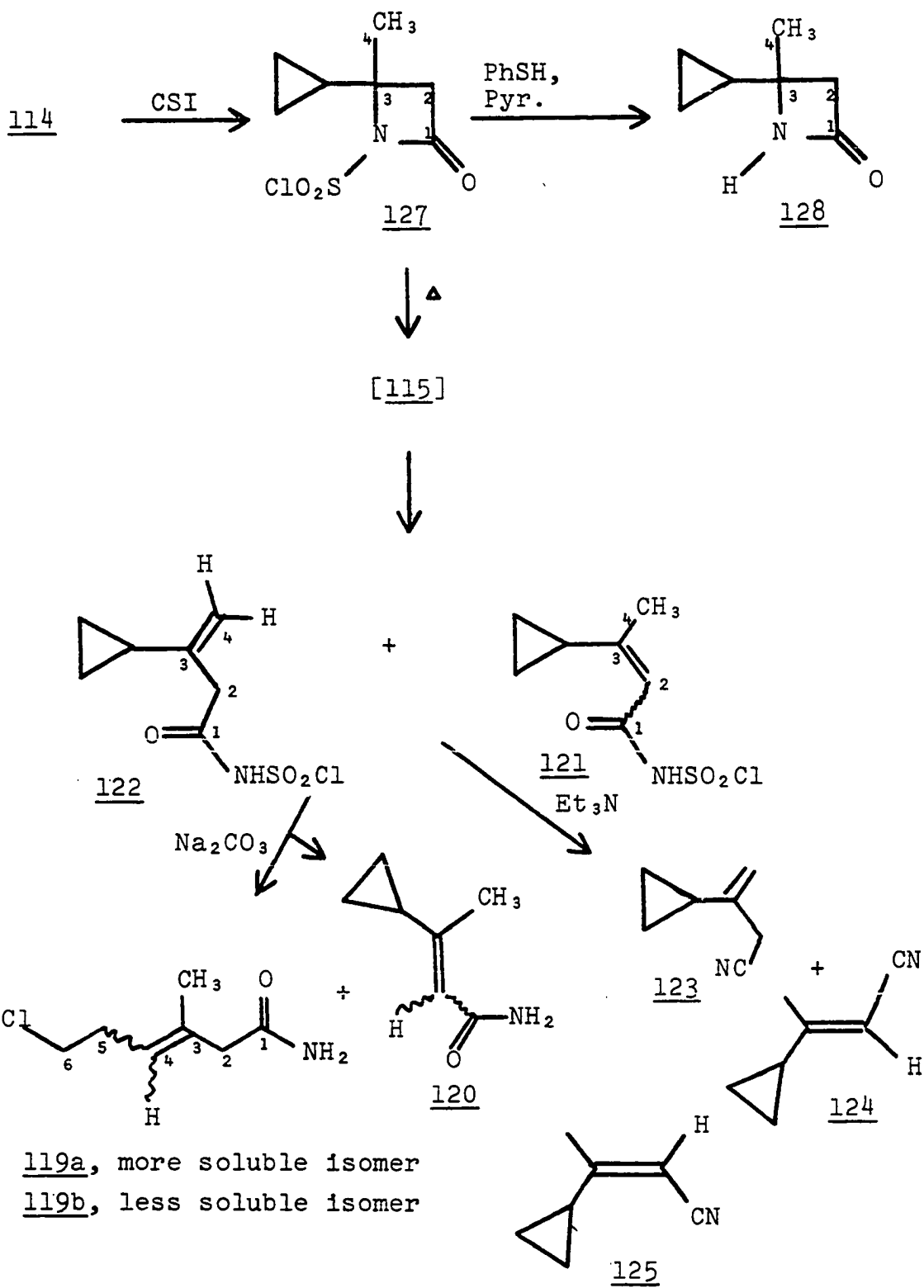

Treatment of the contents of the nmr tube with a saturated solution of sodium bicarbonate gave the nmr corresponding to a mixture of 119a, 119b and 120. This experiment indicates that 119a and 119b are not primary reaction products but are formed by the addition of hydrochloric acid formed by hydrolysis of NSO_2Cl to amide 122 or its reduced form.

Since only one of the ultimate products of the reaction of CSI and 114 had been fully characterized, conversion of the primary reaction products 121 and 122 to separable derivatives was essential. The known conversion of NCS-amides to the corresponding nitriles was chosen. Reaction of CSI with 114 and treatment of the resulting reaction mixture with triethylamine gave a mixture of isomeric nitriles 123-125. These nitriles had been reported previously (52) as a mixture of isomers 123, 124 and 125 or as a mixture of isomers 124 and 125. The ir bands of the nitrile groups were reported (123, 2247 cm^{-1} ; 124 and 125, 2217 cm^{-1}) without reference to phase or solvent. No nmr spectra were reported. This mixture was separated by preparative gas chromatography and are numbered with respect to increasing retention time.

Assignment of 123 as the structure of the least polar isomer was unambiguously based upon ir (neat film, ν_{CN} 2250 cm^{-1}) nmr and high resolution mass spectral data. The structures of 124 and 125 were assigned based on comparison

of their nmr's with that of nitrile 126 (5), Figure 3. This assignment is also consistent with the cis arrangement of the more electron donating cyclopropyl group and electron withdrawing nitrile group to the most polar isomer. Their ir [(film) ν_{CN} 124, 2220 cm^{-1} , 125 2210 cm^{-1}] and high resolution mass spectrum support the structural assignment. Thus the structures of nitriles 123-125 establish the structure of primary reaction products 121 and 122.

Only one case where an unstable NCS- β -lactam was proven to be a precursor to an unsaturated NCS-amide product (2) (see reaction of CSI with α -methylstyrene, p. 10) had been reported and this was thought to be an exception (4).

Interest developed in investigating the applicability of this mechanism to the above case. If NCS- β -lactam 127 was an intermediate in the reaction of CSI with 114 it was felt that there would be a particularly good chance of trapping or observing 127 since it should not be particularly unstable and could be formed at low temperature due to the high reactivity of 114 toward CSI.

Reaction of CSI with 114 at -78° and thiophenol-pyridine reduction at -40° gave β -lactam 128 in 53% yield as the only isolated product. Structural assignment follows unambiguously from the ir, $\nu_{\text{CO}} = 1760 \text{ cm}^{-1}$, nmr (CCl_4) δ 7.27 (broad, NH), 2.50 (d, $J = 1.5 \text{ Hz}$, H-2), 1.42 (s, H-4), 1.30-0.20 (m, cyclopropyl H): mass spectrum m/e 125(p^+)

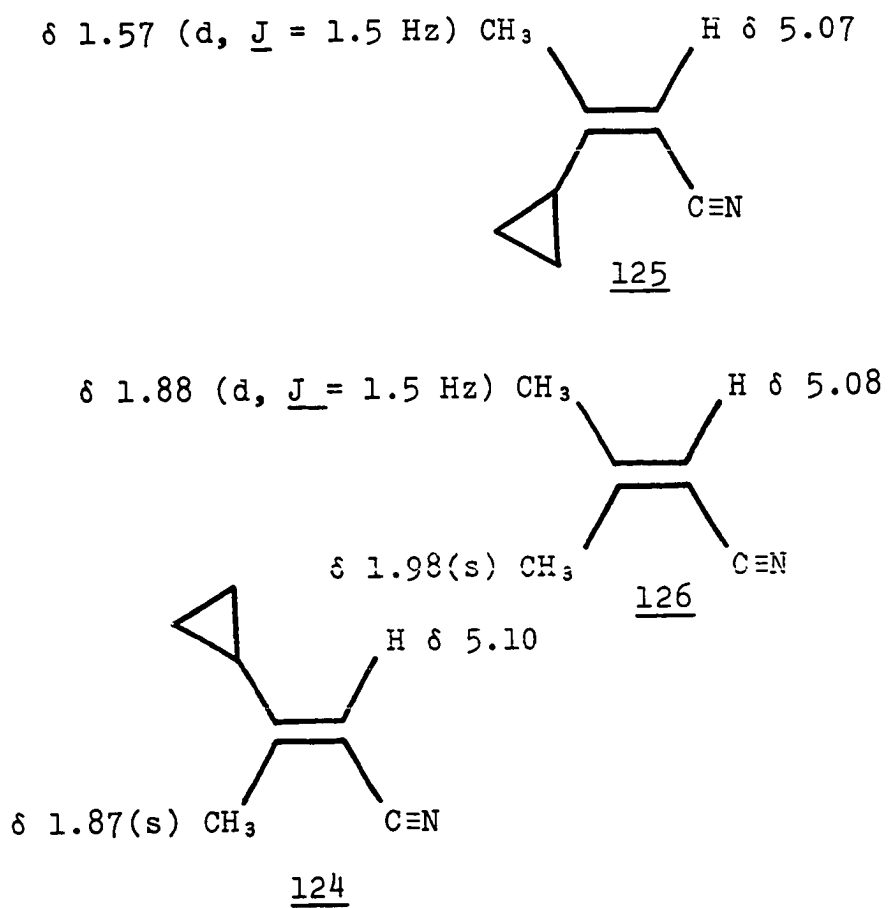

Figure 3. Nmr assignment of nitriles 123 and 124

and acceptable chemical analysis. That the splitting observed in H-2 is due to long range coupling with N-H was verified by collapse of H-2 to a singlet caused by irradiation of the N-H absorption. That only 128 is formed when low temperature reduction conditions are employed implies that 127 is an intermediate in the formation of 121 and 122.

Low temperature nmr study of this reaction conclusively proved this hypothesis. Admixture of equimolar amounts of 114 and CSI in deuteriochloroform at -78° gave rise to the spectrum of a single product which did not change from -65° to -16° : nmr (-16°) δ 2.94 (s, H-2), 1.79 (s, H-4), 1.75-1.28 (m, H-5), 1.00-0.40 ppm (m, H-6 and H-7). The structural assignment of this spectrum to 127 was made with confidence based upon comparison with the nmr spectrum of 128. When warmed to -30° the appearance of equal intensity singlets at 4.98 and 3.26 previously assigned to 122 were observed. Further warming gave the spectrum of 121 and 122 along with the disappearance of 127. The results are given in Table 6. Warming to room temperature gave only the spectrum of 121 and 122.

After publication of this work, Pasto and Chen (53) reported the reaction of CSI with 129 and 133 without reference. Since they were seemingly unaware of the possibility of prior NCS- β -lactam formation, no effort toward detection of their possible intermediacy was reported.

Table 6. Low temperature nmr study of the 2-cyclopropylpropene (114)-CSI reaction

<u>Temp</u>	<u>Chemical Shift</u>	<u>5.87</u>	<u>4.98</u>	<u>3.26</u>	<u>2.94</u>	
-3°		1	4	5	42	
-3°		1	3	4	41	
0°		-	4	5	35	
0°		-	6	6	35	
0°		-	4	5	26	
0°		1.5	10	12	39	Integration
0°		2.0	13	14	34	
0°		2.5	15	16	31	
0°		2.5	18	19	26	
0°		3.0	21	20	21	

Paquette *et al.* (54) reported CSI reaction with bicyclic vinylcyclopropanes 131, 132 and 54. The formation of 55 was postulated to involve trans-1,3-bishomotropilium ion 53. A conclusion that can be drawn from the reaction of 114 and 129 with CSI is that attack of $(\text{NSO}_2\text{Cl})^-$ on the β -ring carbons in intermediates of type 115 must be much slower than loss of proton. Reaction 133 or 54 with CSI involves rearrangement of first formed dipolar intermediates 134 and 135 respectively to 136 and 53. This pathway is favored in these cases by presence of electron donating groups at the β -cyclopropyl carbons. In the case of 112, 127 or 138 there is no evidence currently available necessitating a dipolar intermediate.

Attention was then turned to reaction of CSI with methylenecyclopropane (139a). Initial investigation led to the conclusion that CSI reaction with 139a was very slow at room temperature. This was unsuitable for investigation since either possible NCS- β -lactam intermediate was bound to be thermally unstable due to ring strain and would probably undergo rearrangement at a rate comparable to its formation.

Aue (55) reported that the rate of CSI reaction with 1-methylcyclopropene was greater than 2.1×10^4 more rapid than CSI reaction with 139a. Also, electrophilic attack occurred at C-2 which gave rise to ring enlarged product 140.

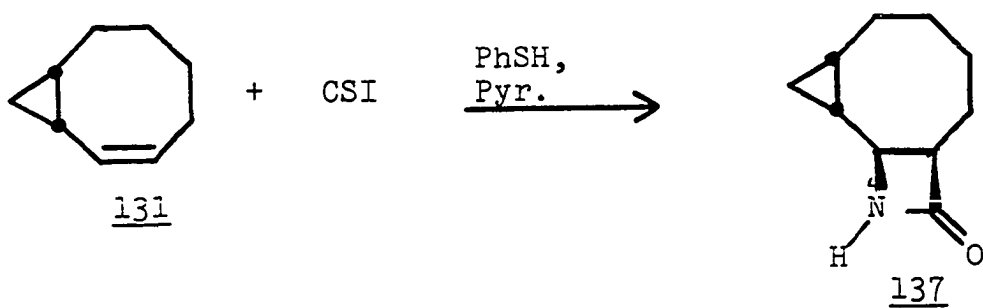
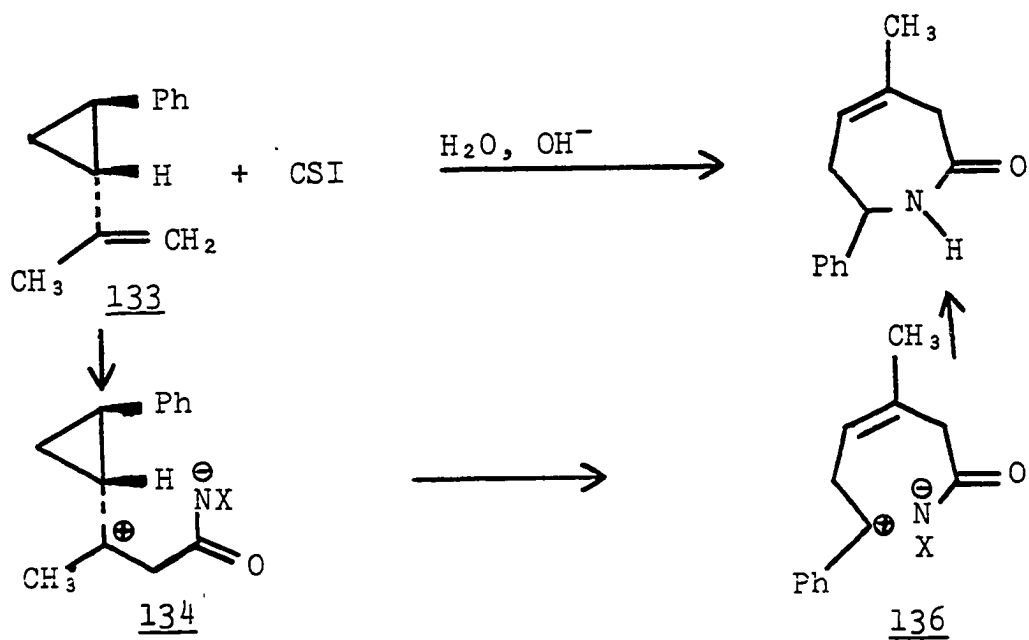
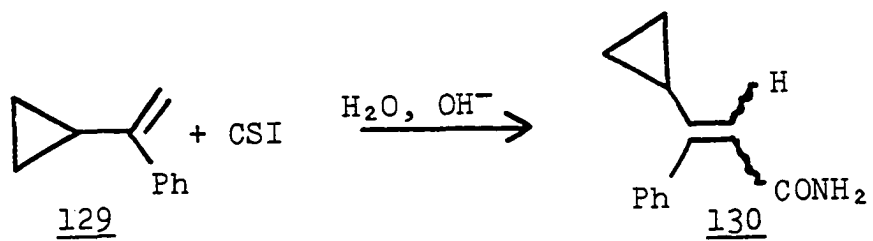

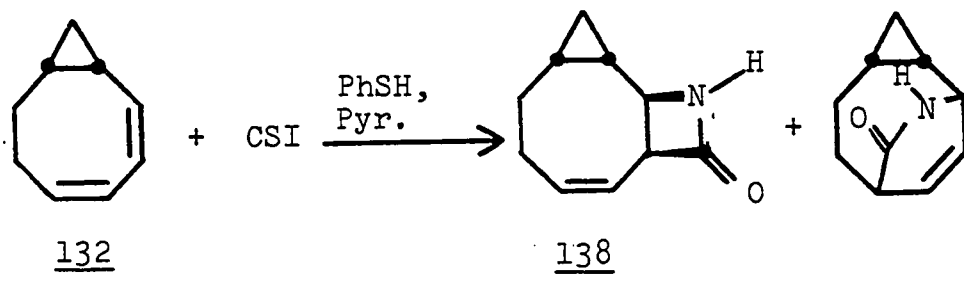

X = SO₂Cl

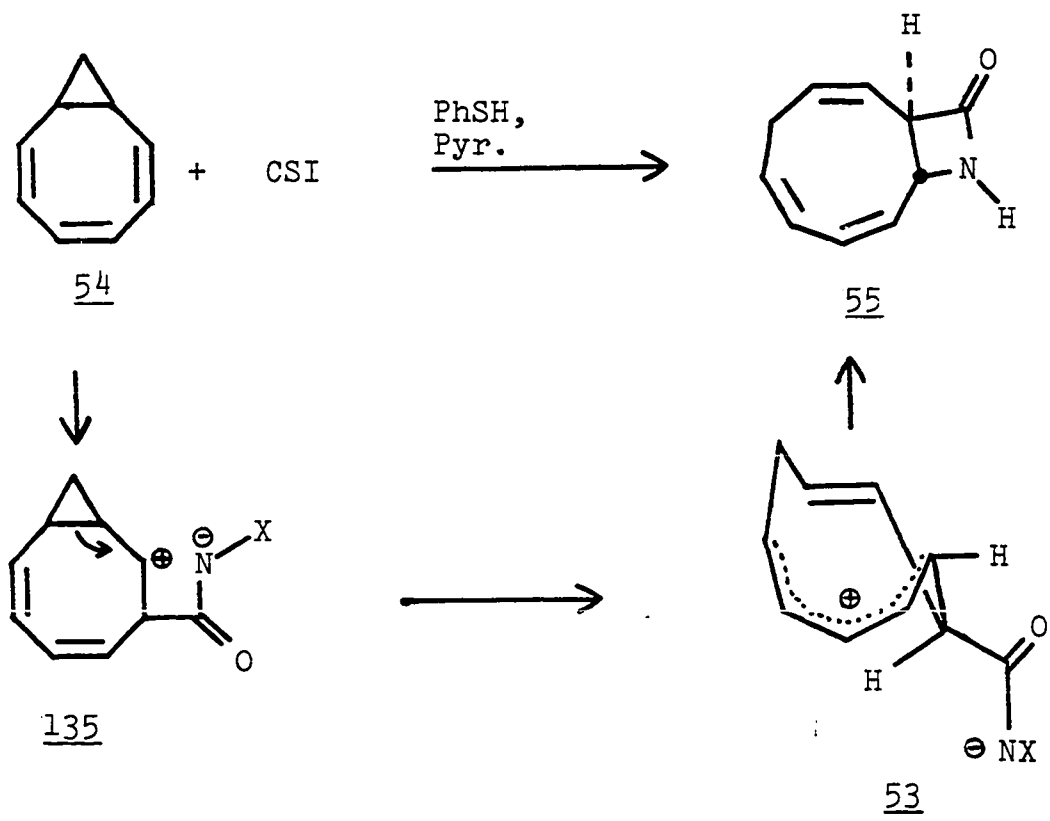

X = SO₂Cl

From solvolysis rates of cyclopropylcarbinyl bromide (0.34 hr^{-1} , 25° , 50% ethanol-water) (56) and cyclopropyl bromide ($9.30 \times 10^{-12} \text{ sec}^{-1}$, 25° , 50% ethanol-water) (57) attack at C_1 would have been expected. However, the addition of CSI to 139a would generate positive charge in an orbital which is rotated 90° from the most stable bisected geometry for cyclopropylcarbinyl cations.

In order to insure initial CSI attack at C-1, thus generating positive charge at cyclopropylcarbinyl carbon C-2, reaction of CSI with diphenylmethylenecyclopropane (139b) was decided upon. At the time this study was about to commence, Dunkelblum (58) reported that reaction of CSI with 139b gave iminolactone 141 exclusively. He argued that olefin 139b should be sterically hindered and therefore allowed the reaction to proceed "overnight" at room temperature. Formation of dipolar intermediates 142 and 143 was rationalized as being due to strain relief. It was decided that reinvestigation of this reaction was in order since the author would have predicted reaction of CSI and 139b to be much faster than indicated and hence allow detection of strained NCS- β -lactam 144.

Admixture of equimolar amounts of CSI and 139b in deuteriochloroform resulted in rapid reaction which was monitored by nmr. The reaction gave a single product: nmr δ 7.33 (s, 10H), 1.60 (m, 2H), 1.10 ppm (m, 2H). The

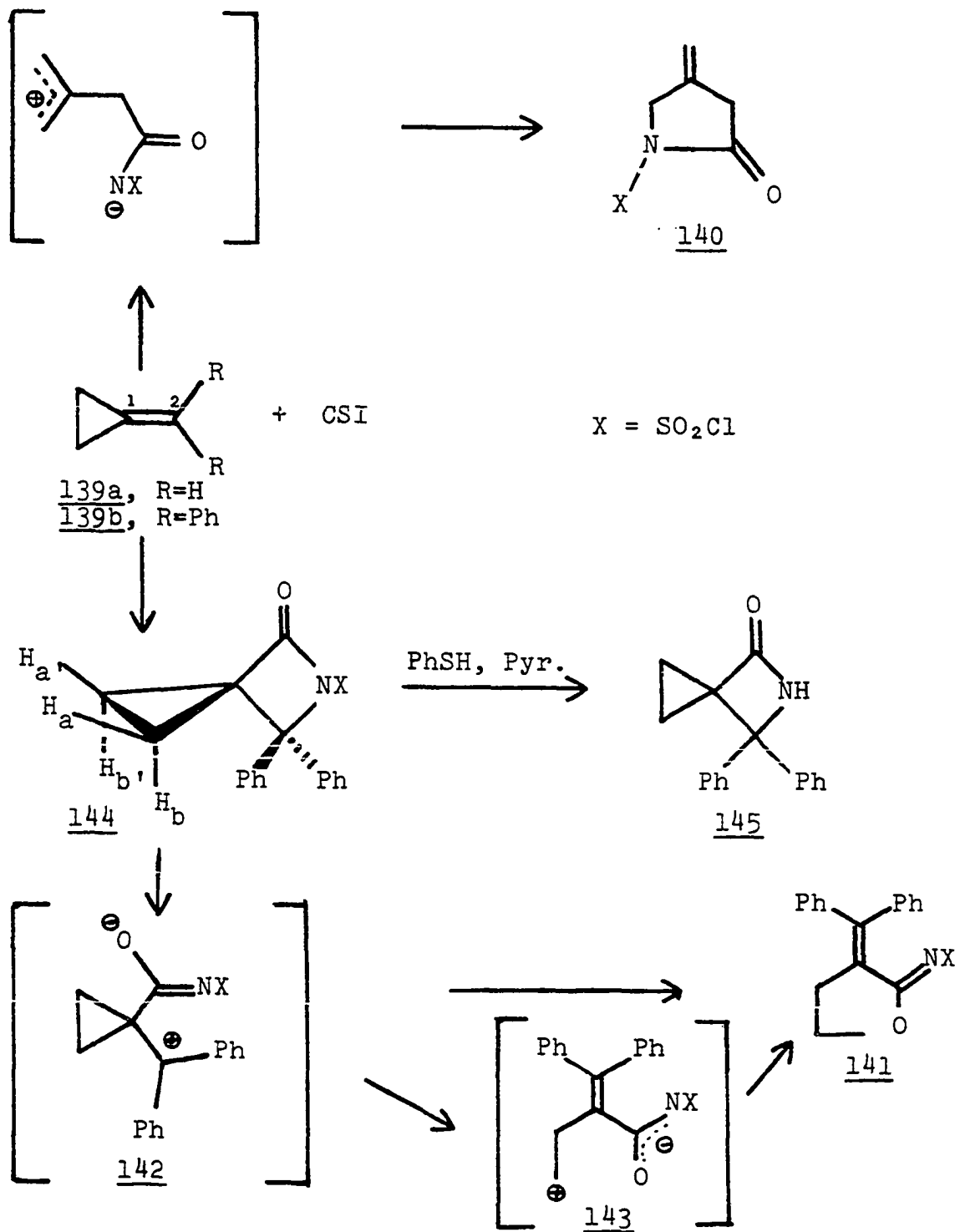

upfield multiplets exhibited an AA'BB' pattern as expected for 144 since each multiplet was unsymmetrical and there was a plane of reflection between them (59). The ir spectrum of this reaction mixture supported this interpretation since only one band at 1828 cm^{-1} as expected for an NCS- β -lactam was present in the carbonyl region. An nmr spectrum of this solution showed total absence of 144 and exhibited the spectrum reported by Dunkelblum for 141 after 24 hr. at room temperature.

Reaction of CSI and 139b at 0° followed by thiophenol-pyridine reduction gave β -lactam 145 as expected. The structure of 145 is unambiguously established by its spectral data.

Clearly diphenylmethylenecyclopropane 139b reacts with CSI to give initially NCS- β -lactam 144 which suffers thermal heterolysis of the C-N bond to form dipolar intermediate 142. Formation of iminolactone most probably results from internal attack of O^- on the β -cyclopropyl carbons of dipolar intermediate 142. Because of the relative stabilities (primary allylcarbinyll vs. tertiary dibenzyl-cyclopropyl-carbinyll cations) of the positive portions of dipolar ions 143 and 142 formation of 141 does not probably involve 143.

Before publication of the preceding work it had been past practice (with the notable exception of Moriconi) for chemists investigating CSI additions to either claim or

imply direct formation of dipolar intermediates based solely upon the rearranged nature of the final reaction products. Since publication of our work investigators now look for NCS- β -lactam intermediates and observe them with which at one time would have been considered surprising regularity (22,26,28,60,61).

Study of the reaction of CSI with cyclobutene (146); 3,3-dimethylcyclobutene (147); 1,2-dimethylcyclobutene (148), 1-methylcyclobutene (149) and methylenecyclobutane (150) was undertaken. Before discussion of these results, it is appropriate to discuss the major products expected from each bearing in mind that tertiary cyclobutyl cations are more stable than primary cyclopropylcarbinyl cations (62) but that secondary cyclopropylcarbinyl cations are more stable than tertiary cyclobutyl cations (62) and hence tertiary cyclopropylcarbinyl cations are more stable than tertiary cyclobutyl cations.

Reaction of CSI with cyclobutene (146) should give a mixture of products derived from dipolar ions 151 and 152 while 3,3-dimethylcyclobutene (147) should give primary products derived from dipolar ion 153 irrespective of the mode of initial attack. Reaction of CSI with 1,2-dimethylcyclobutene (148) should give principally products derived from dipolar ion 154. Likewise, 1-methylcyclobutene (149) should give product derived from dipolar ion 155. Finally,

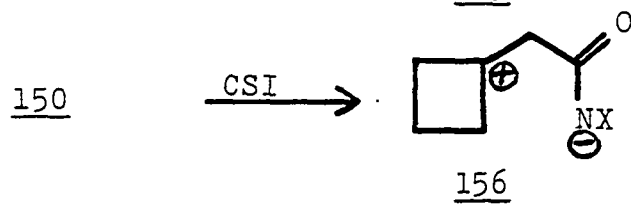
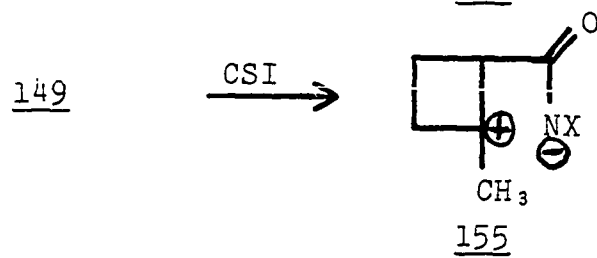
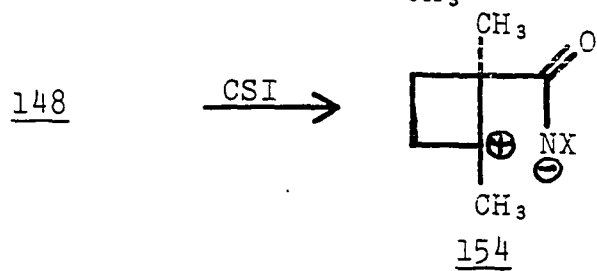
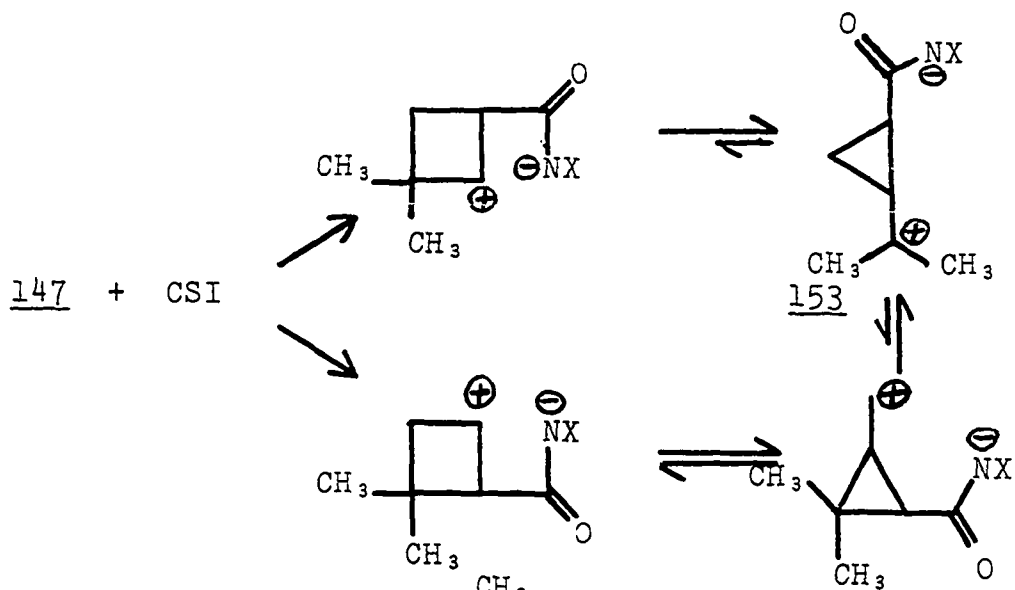
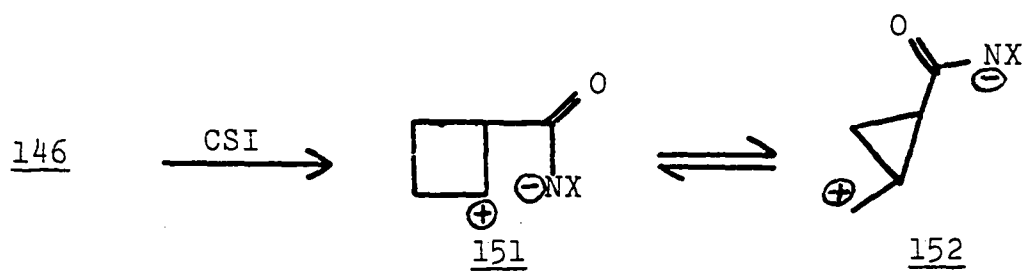
X = SO₂Cl

methylenecyclobutane (150) would be expected to give products derived from dipolar ion 156.

Under typical conditions usually employed for CSI-olefin additions neither cyclobutene nor 3,3-dimethylcyclobutene reacted with CSI. Under more forcing conditions reaction occurred to a slight extent but was accompanied by severe darkening of the reaction mixtures.

CSI reacted smoothly with 1,2-dimethylcyclobutene (148) to give NCS- β -lactam 157a as the only product. Reduction of 157a gave β -lactam 157b. Structural assignments 157a and 157b are consistent with elemental analyses, mass spectral data and the ir frequencies of the carbonyl absorptions which are typical for NCS- β -lactams and β -lactams respectively. That the isolated products were not the mechanistically improbable bicyclic lactams 158a and 158b is shown by the lack of symmetry in the cyclobutyl region of the nmr spectra. The lack of symmetry is typical for an ABCD spectrum expected for 157a or 157b but not for 158a or 158b whose spectra should exhibit complete symmetry about the mean chemical shift (59).

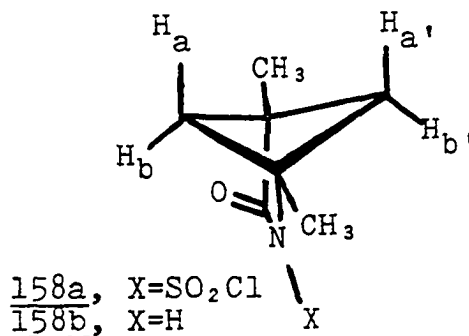
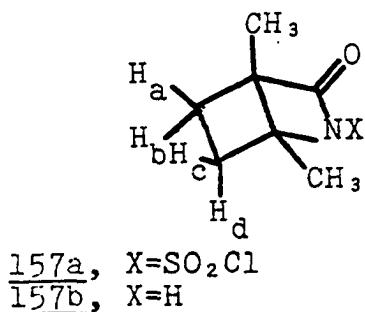

After completion of this work, lactam 158b was reported by Paquette *et al.* (38). It was formed by addition of CSI to 1,3-dimethylbicyclobutane and, surprisingly, had the same physical and spectral properties as observed for 157b. The carbonyl absorption at 1745 cm^{-1} is that of a typical β -lactam and the nmr is reported to reveal the presence of four methylene protons as a multiplet with no mention of the expected AA'BB' pattern. In an effort to establish that 157b and the product isolated by Paquette *et al.* were identical, the reaction of CSI and 1,3-dimethylbicyclobutane was undertaken. Contrary to the impression given by Paquette that the reported compound was the exclusive or at least major isolable product of this reaction, it was found that it was only a minor product of a complex mixture. This observation, along with the assignment of 157a as the structure of the isolated product, has been confirmed by Paquette (63).

Paquette also reported the addition of CSI to other bicyclobutanes and concluded that the reaction of CSI with bicyclobutanes was initiated by heterolytic cleavage of the internal 1,3 bond.

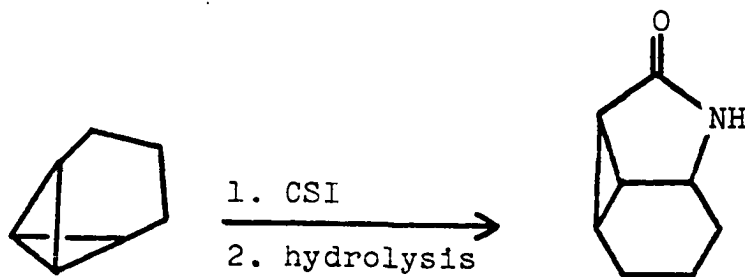

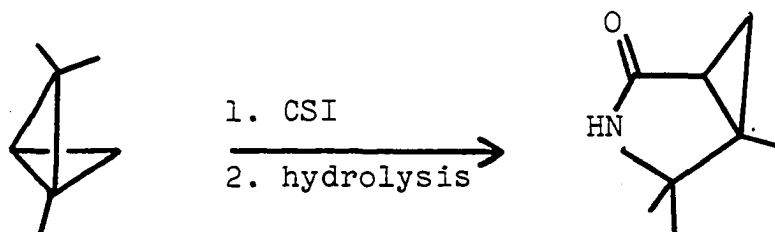
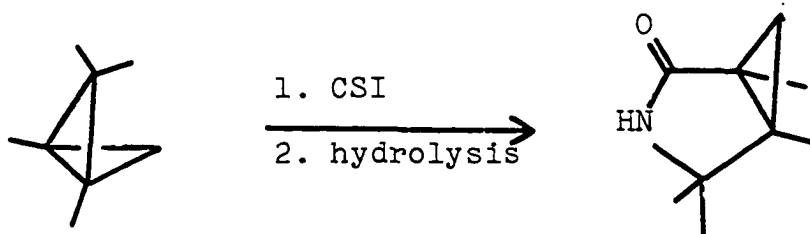

For this mechanism to be operative in the above cases, rearrangement of the first formed dipolar intermediate must be faster than a ring flip since no bicyclo[2.1.1]hexane products are observed in these cases. However, one notes all of the above products can be accounted for equally well by invoking initial cleavage of an edge bond (C_1-C_2) followed by cyclization to the lactam. If this route is operative, no relative rate arguments of cyclobutylcyclopropylcarbinyl rearrangements versus conformational inversion are necessary to explain the absence of bicyclo[2.1.1] products. This pathway also explains the formation

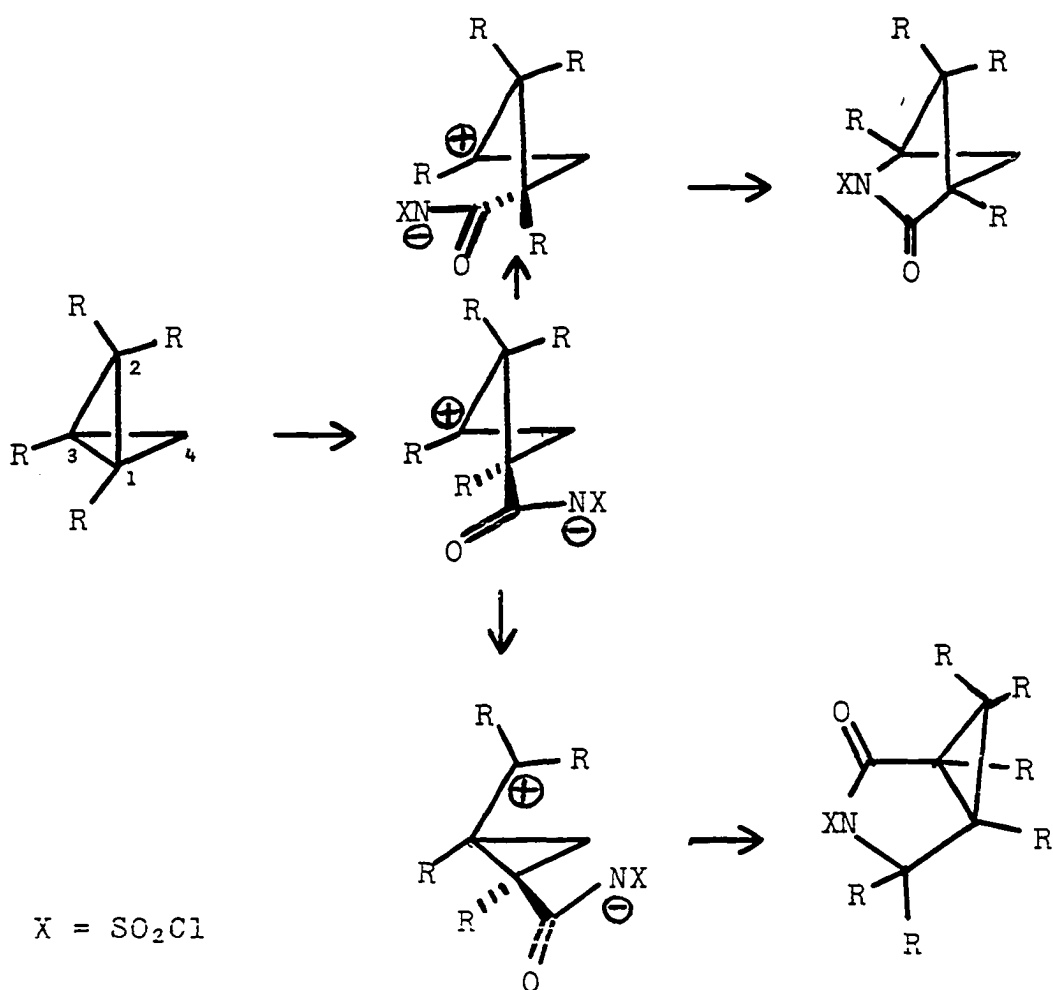

of NCS- β -lactam 157a from the addition of CSI to 1,3-dimethyl-bicyclo[1.1.0]butane. Cleavage of the C₁-C₂ bond would immediately yield a dipolar intermediate containing a primary cyclopropylcarbinyl cation. Since as previously mentioned the tertiary cyclobutyl cation is known to be more stable than a primary cyclopropylcarbinyl cation, ring expansion to dipolar intermediate 154 would be expected.

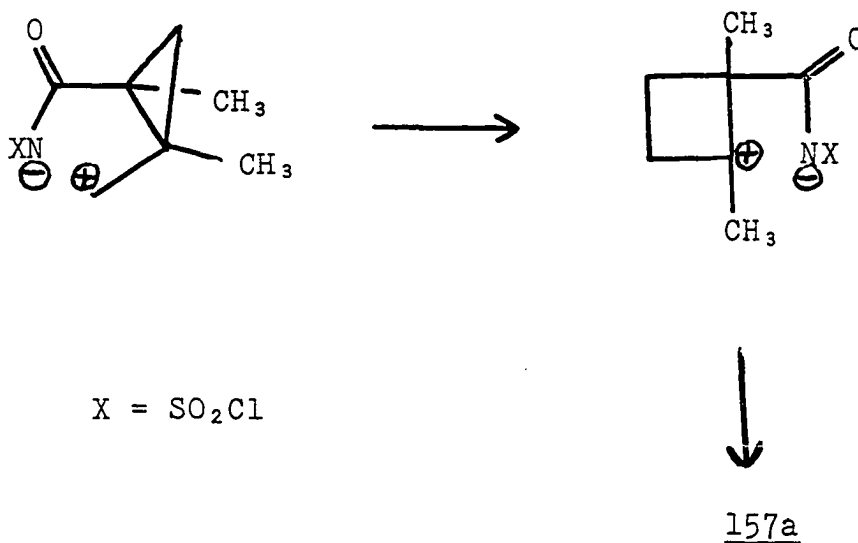

Reaction of CSI and 1-methylcyclobutene gave β -lactam 159b along with variable and small amounts of other compounds. The structure of 159b is based upon mass spectral, high resolution mass spectral and infrared data. Its nmr spectrum is consistent with structural assignment 159b based on analogy with the spectrum of 157b.

Reaction of CSI with methylenecyclobutane gave spiro- β -lactam 160b as the only observable product after standard base treatment. Structural assignment 160b is supported by ir, mass spectral, high resolution mass spectral and nmr data. The splitting (d, $J = 2\text{Hz}$) observed for the β -lactam protons (CH_2 , C=O) is attributed to long range coupling

with the NH proton. This is supported by the observed collapse of the doublet to a singlet when the NH absorption was irradiated.

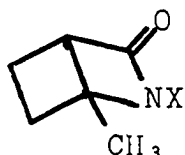

159a, X = SO₂Cl
159b, X = H

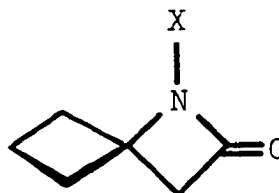

160a, X = SO₂Cl
160b, X = H

Cyclobutene and 3,3-dimethylcyclobutene should react more readily with CSI than acyclic disubstituted olefins due to relief of strain if direct formation of free dipolar intermediated occurred. Their surprising lack of reactivity might indicate strain increase in the transition state. A transition state closely resembling transition state 8 is consistent with this interpretation.

Since it is now quite apparent that NCS- β -lactams could be successfully observed and trapped in cases where rearrangement or elimination products were ultimately formed, it was felt that the reaction of CSI with silole 90 merited reinvestigation. Additions of equimolar amounts of CSI and silole 90 in deuteriochloroform gave an nmr spectrum assigned

to NCS- β -lactam 91 and a minor amount of 103. The nmr absorptions due to 103 increased relative to those of 90 until iminolactone 103 precipitated from solution. Reaction and reduction at 0° gave expected β -lactam 161 in good yield.

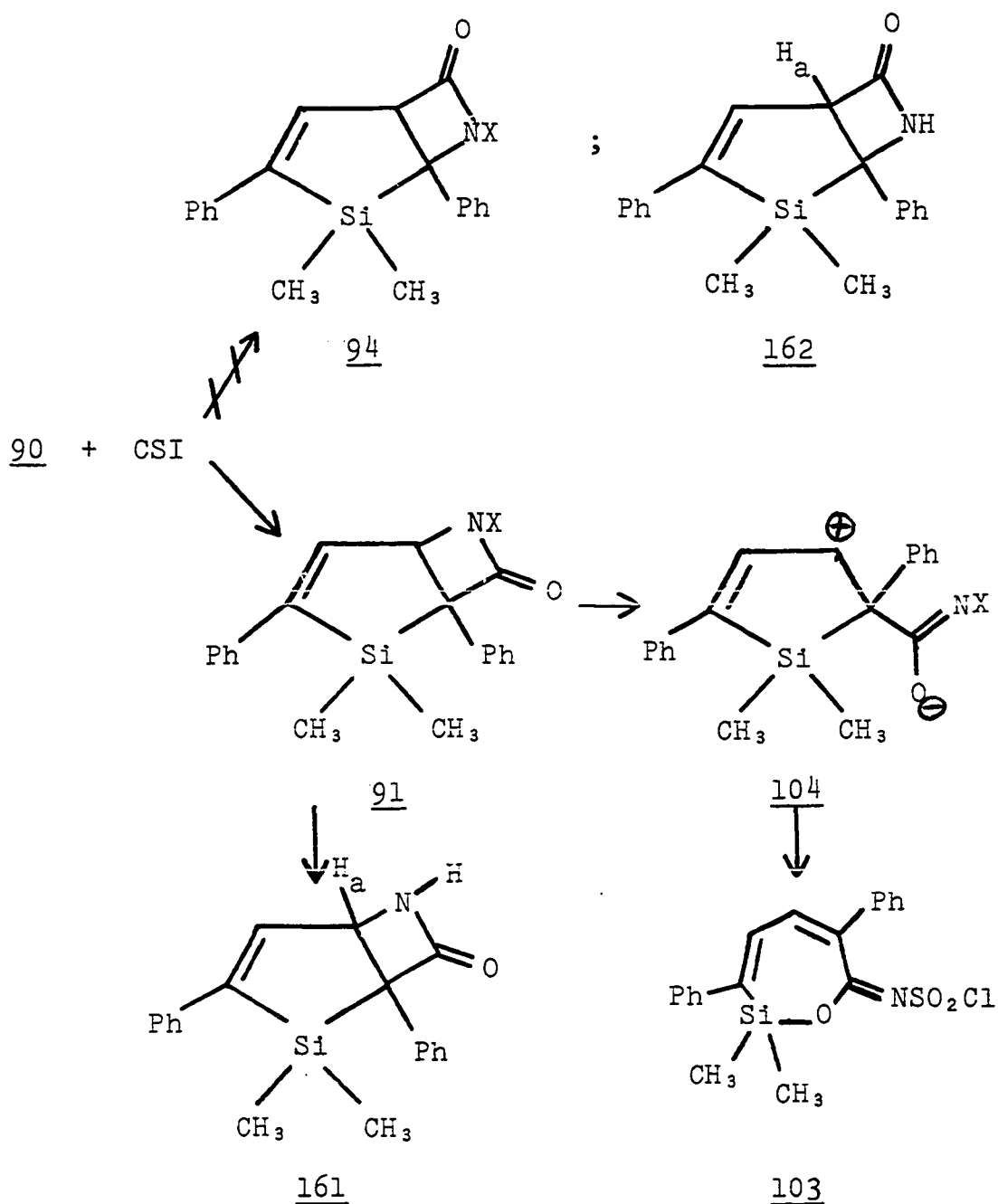

Structure 161 is favored over 162 based upon the following argument. Ketone 163 (47) has its H_a nmr absorption at 4.49 ppm. From chemical shift correlation tables (39, p 137) H_a of 161 is predicted to absorb at δ 4.69 ppm ($4.49 + 0.20$) while 162 is predicted to absorb at δ 4.29 ppm ($4.49 - 0.20$). The β -lactam assigned structure 161 has its H_a signal at δ 4.69 ppm. Thus, structure 161 is favored but not absolutely proven.

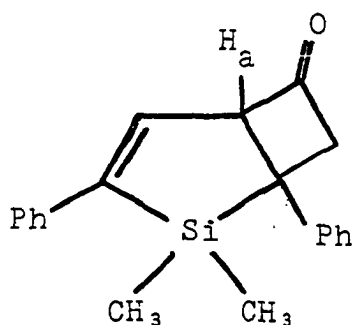
163

In order to further substantiate this structural assignment, an unambiguous synthesis of β -lactam 162 was attempted. Reaction of CSI with silacyclopentene 164 should occur to give only β -lactam 165 after thiophenolpyridine reduction. Treatment of 165 with 2,3-dichloro-5,6-dicyanoquinone (DDQ) would then give β -lactam 162. Hydrogenation of silole 90 gave a mixture of reduced material composed of 92% 164. Silacyclopentene 164 was characterized by its nmr, high resolution mass spectrum and conversion to pure epoxide 166. Silacyclopentene 164 failed to react with CSI of proven

purity even when heated to 75° for 24 hr. The failure of 164 to react with CSI lends further support to structure 161. If initial attack of CSI had occurred at C-3 of 90 and formed 94, then 164 should have reacted at least as rapidly as 90 since the additional carbon-carbon double bond should have little effect on the reaction rate.

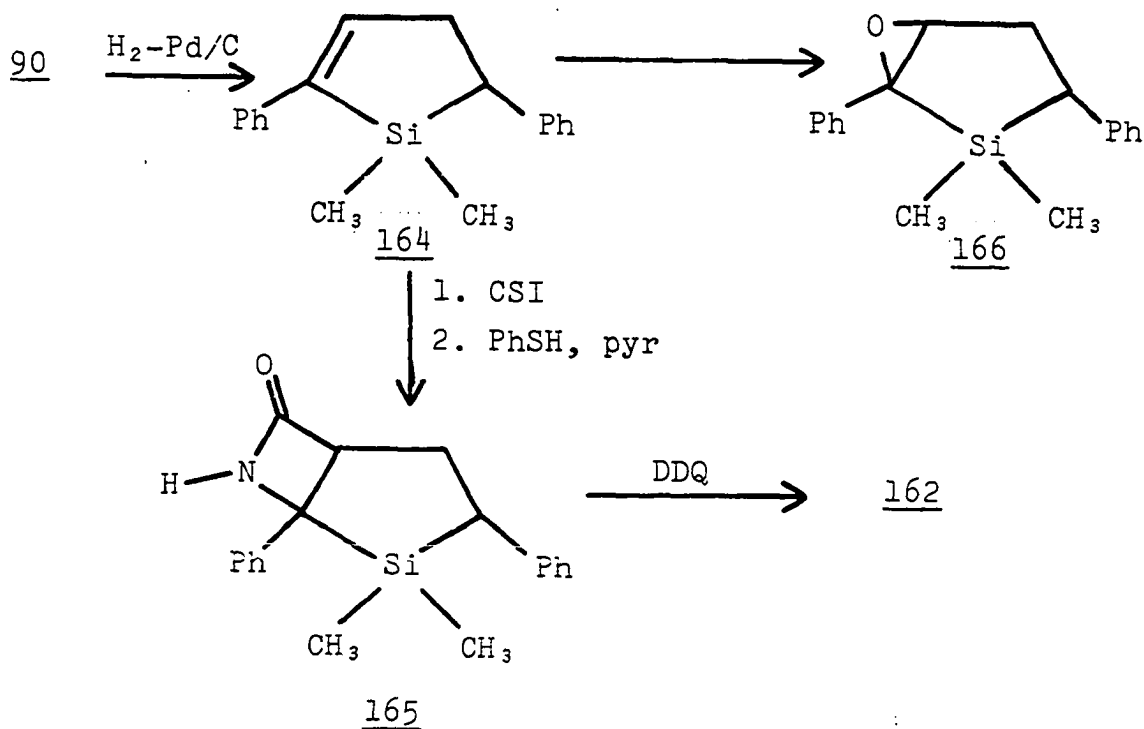

Structure 161 was further substantiated by an nmr-shift reagent study (Table 7). If the isolated β -lactam had structure 126 then $\Delta\delta$ for H_a should have been ca. 1.3 times greater than H_b. The observed ratio for $\Delta\delta$ of 0.52 is in better agreement with structure 161. The comparatively large values of $\Delta\delta$ for H_d, H_e, H_f and small value for H_c are also in better accord with structure 161. Thus, it can

Table 7. Shift reagent study [Pr(Fod)₃] on β-lactam 161

<u>[Pr(Fod)₃]</u> <u>161</u>	H _e	H _f	H _a	H _b	H _c	H _d	
0.000	-0.07	0.52	4.63	6.77	6.93	7.20	
0.046	-0.31	0.11	4.07	5.79	6.68	6.63	chemical shifts ^a
0.091	-0.59	-0.35	3.52	4.66	6.47	6.01	
0.046	-0.25	-0.41	-0.56	-0.98	-0.25	-0.57	
0.091	-0.52	-0.87	-1.10	-2.11	-0.46	-1.19	Δδ ^b

^aChemical shifts with respect to tetramethylsilane internal standard in deuteriochloroform expressed in δ ppm units.

^bChange in chemical shift due to Pr(Fod)₃.

be concluded that NCS- β -lactam 161 is an intermediate in the formation of iminolactone 99. The pathway from 161 to 99 most logically involves dipolar intermediate 104.

CONCLUSION

It would be appropriate to review results and claims in the literature critically, with the aim of proposing a mechanism which accounts for these results and leads to a better understanding of CSI-olefin reactions.

It is clear from the extensive kinetic investigation of Clauss (2) that any proposed mechanism must account for extensive charge separation in the transition state. Thus, a diradical mechanism or a synchronous concerted mechanism can be eliminated from further consideration. The need to account for charge separation led Graf (4) to propose his dipolar mechanism (direct formation of a dipolar intermediate). This mechanism fulfilled the need to explain elimination (unsaturated NCS-amide) and rearrangement products which often accompany NCS- β -lactam products in CSI-olefin additions. His mechanism was also supported by Graf's (4) claim that NCS- β -lactam and unsaturated amide products are formed in a constant ratio throughout the reaction.

The addition of CSI to α -methyl styrene (29) (2) which gave ultimately unsaturated NCS-amide product was known to involve prior formation of NCS- β -lactam 28 but was dismissed as an exception. However, the various examples indicating

prior formation of NCS- β -lactam products in reactions which lead ultimately to formation of iminolactone rearranged lactam and unsaturated amide products cited in the Introduction along with the authors observation of prior formation of NCS- β -lactam 127 in the addition of CSI to 2-cyclopropylpropene render Graf's mechanism as an exclusive pathway untenable.

Although dipolar ions have been postulated by many authors as intermediates in CSI-olefin additions, the exact nature of these intermediates is not usually discussed. It is clear that solvated free dipolar ions (ions in which the C-3 nitrogen distance in 7 is significantly larger than the C-3 nitrogen distance in 2) are not intermediates in NCS- β -lactam formation. This is supported by the stereospecific nature of CSI-olefin additions and overwhelming preference for initial 1,2 over 1,4 closure in CSI-diene reactions. If one assumes that a free dipolar ion is formed initially, it is not expected that closure to a four-membered ring should proceed exclusively over formation of a six-membered ring (64).

Dipolar intermediates of type 167 and 168 once proposed by Moriconi and Crawford (12) in order to explain the absence of rearrangement products in the reaction of CSI to various norbornenes may be intermediates in CSI-olefin reactions.

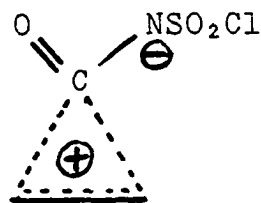
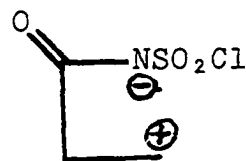
167168

Intermediates 167 and/or 168 can account for the stereospecific nature of CSI-olefin additions. Also, preferential collapse of 167 and/or 168 to 1-2 versus 1-4 ring closure products in the addition of CSI to dienes might be explained by the principle of least motion (65). Formation of elimination, rearrangement or oxygen closure products can be explained by formation of a free dipolar intermediate from 167 and/or 168 either simultaneously with NCS- β -lactam formation or as a consequence of ring opening of an unstable NCS- β -lactam intermediate. Differences between the above pathway and a nonsynchronous concerted pathway are semantic in nature and not easily distinguishable.

Recent reports have appeared in the literature of data which has been interpreted as evidence against a nonsynchronous concerted pathway. Malpass and Tweddle (22) reported that camphene (23) and α -fenchene 169 react with

CSI at a comparable rate at -60° . Whereas camphene leads to formation of NCS- β -lactam 27a at -60° , under identical conditions α -fenchene does not give observable concentrations of NCS- β -lactam 170 but only rearranged products 171 and 172. These results are explained by initial formation of dipolar ions in both cases. It is claimed that the usual kinetically controlled formation of NCS- β -lactam does not occur for intermediate 173 since the syn-7-methyl group inhibits approach of the bulky chlorosulfonyl group.

Obviously, failure to observe NCS- β -lactam 170 under their reaction conditions does not mean that it was not formed. Lactam 170, if formed, would be expected to be more unstable toward formation of dipolar intermediate 173 than 27a is toward formation of 26 because of unfavorable steric interaction of the syn-7-methyl group and the bulky chlorosulfonyl group. Also, rearrangement to 173 will be favored over rearrangement to 26 since the positive charge in 173 is stabilized by β -dimethyl substitution. Malpass and Tweddle (26) also intimate that formation of NCS- β -lactam 39a from iminolactone 40 constitutes proof against a concerted reaction mechanism. Formation of NCS- β -lactams by a nonsynchronous concerted mechanism in no way implies that NCS- β -lactams cannot be formed from dipolar intermediates in other processes.

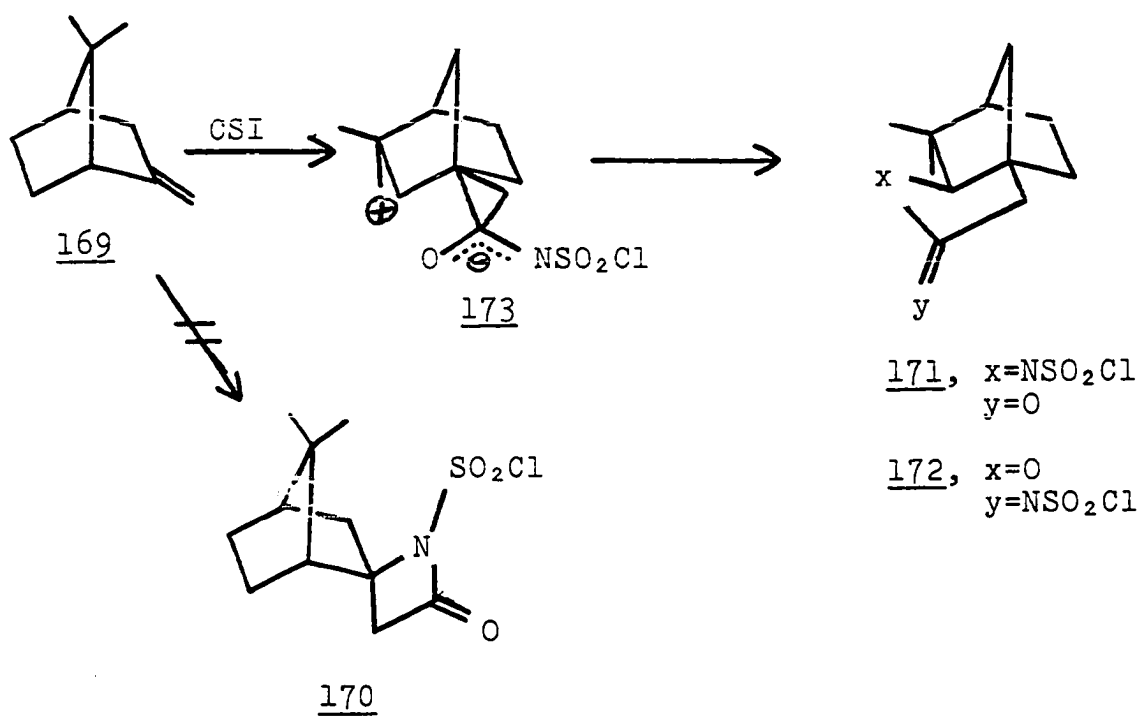
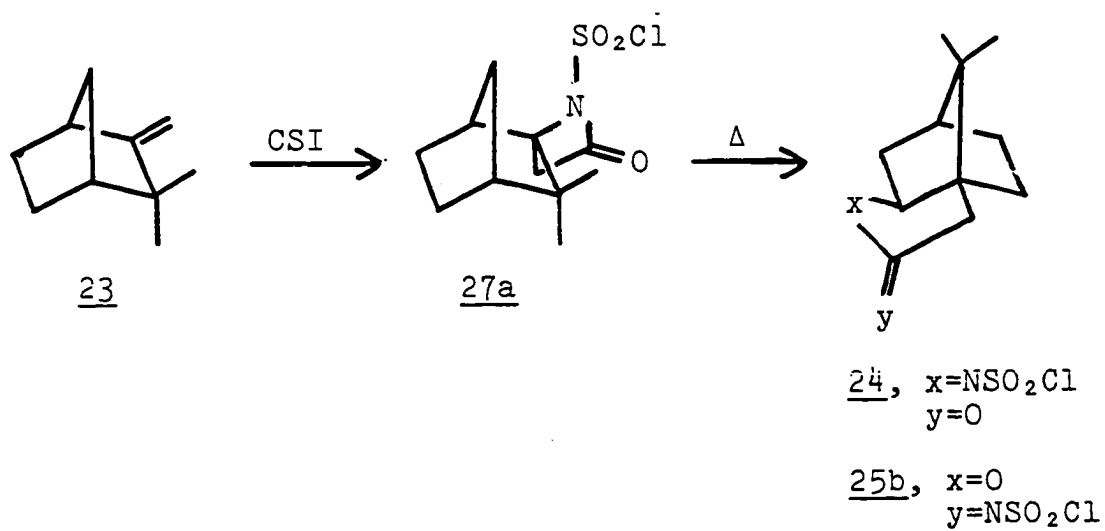

It is very difficult to understand the intimate details of Malpass' mechanisms since the term dipolar intermediate is not further defined. What is clear, however, is that Malpass favors direct formation of some type of dipolar intermediate. In cases where NCS- β -lactam intermediates precede rearrangement, elimination or oxygen closure, Malpass accounts for this as kinetic preference for closure to NCS- β -lactam over the other processes (22,26). If a free dipolar ion is meant, there is no logical explanation why NCS- β -lactam formation should be kinetically favored.

Although most of the data concerning CSI-olefin additions can be accommodated by proposing two or more different mechanisms, it would be preferable if the data could be explained by one general mechanism. A mechanism that attempts this follows.

Addition of CSI to all olefins commences with an initial attacking geometry which resembles transition state 8 strongly. Besides the energetic advantages of a concerted mechanism, this geometry has electrophilic CSI attacking the electron-rich surfaces of the olefin in such a manner as to minimize unfavorable steric interactions between the bulky chlorosulfonyl group and the olefinic substituents and minimize the distance between the partially charged centers. If the structure of the olefin is of the type where positive charge buildup is taking place at a carbon where the charge is not

delocalized either by a conjugated π system or by a participating carbon-carbon sigma bond then the addition may proceed to give NCS- β -lactam product stereospecifically or leakage from the dipolar transition state to a discrete dipolar ion from which unsaturated NCS-amide is formed. In cases where the NCS- β -lactam formed is stable to the reaction conditions the ratio of the two products will be constant throughout the additions. This would explain Graf's results (4). In cases where initial NCS- β -lactam product is unstable to the reaction conditions, it may open to the same dipolar intermediate which then goes on to unsaturated NCS-amide product. This would

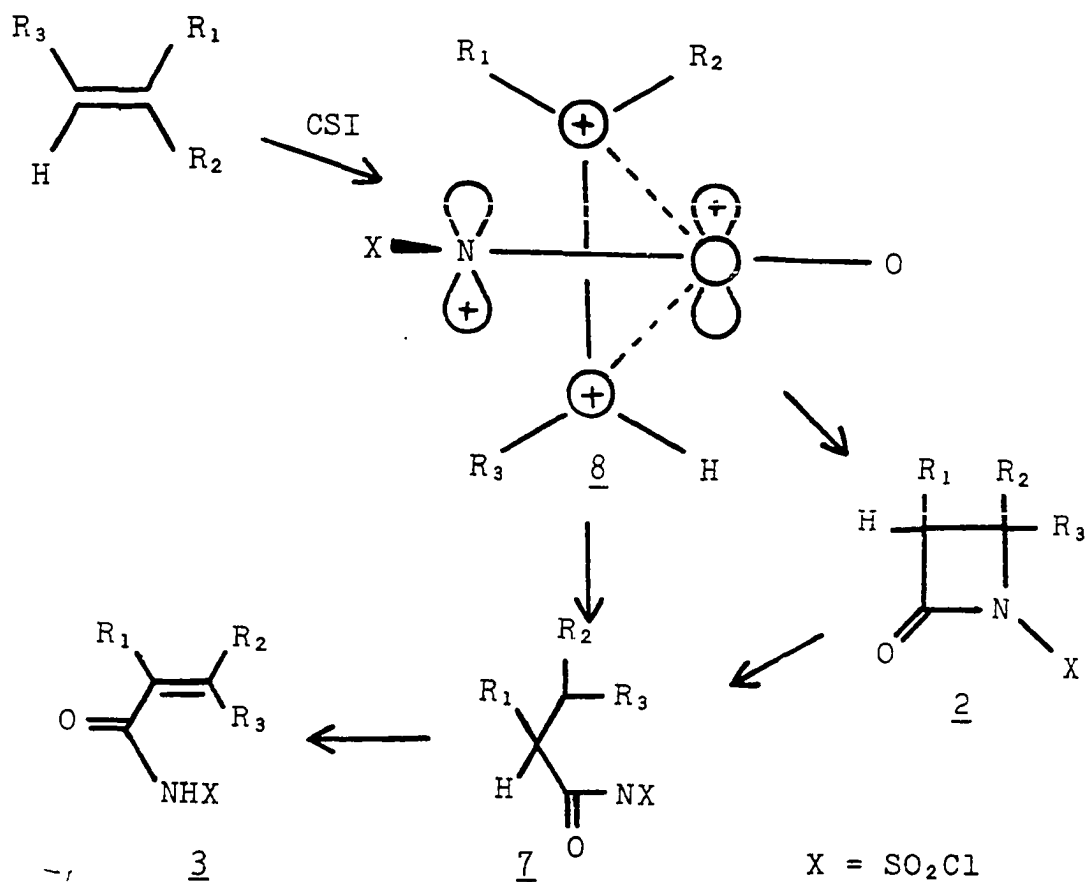

explain the results reported for the 2-cyclopropylpropene-CSI reaction in this dissertation. Also, this mechanism could account for cases where unsaturated NCS-amide and unstable NCS- β -lactam are formed simultaneously.

If the structure of the olefin is of the type where positive charge buildup leads to an irreversible rearrangement, then the dipolar transition state will proceed directly and irreversibly to give a rearranged dipolar ion and no NCS- β -lactam product. This would explain the results reported for the reaction of CSI and cyclopropenes presented in this dissertation.

Finally, if the structure of the olefin is of the type where positive charge buildup is delocalized by a conjugated system or a participating carbon-carbon sigma bond, positive charge in the dipolar transition state will be delocalized. Since the negatively charged nitrogen is still closer to the original double bond carbon, CSI shows a kinetic preference for NCS- β -lactam formation. If no leakage occurs and the NCS- β -lactam is stable to the reaction conditions, then it will be the only product. The reaction of norbornene which gives only β -lactam 174 is an example of this case.

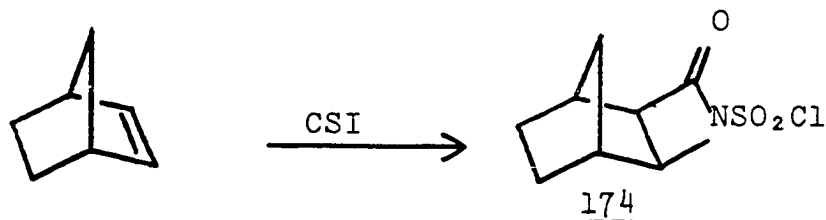

If the initially formed NCS- β -lactam is unstable to the reaction conditions, it may open to a dipolar intermediate which goes on to rearranged products. The addition of CSI to camphene 23 is an example of this case. At -60° NCS- β -lactam 27a is the only product (kinetic product). At higher

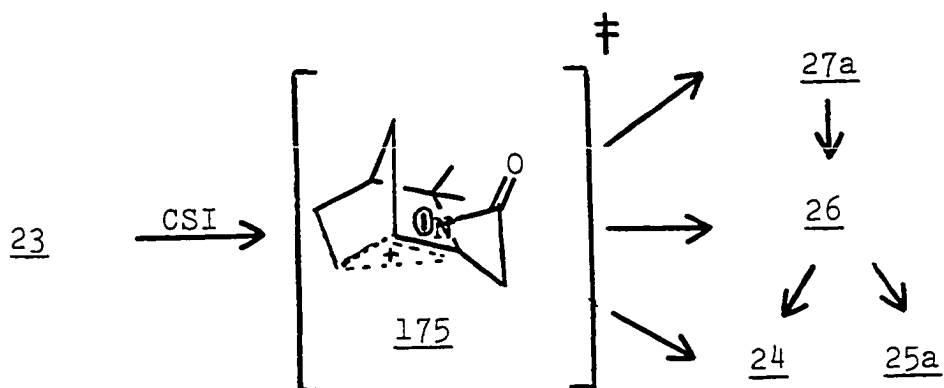

temperatures (where NCS- β -lactam 27a is unstable) direct closure of transition state 175 to NCS-lactam 24 and leakage to discrete dipolar ion 26 may compete with formation of 27a. Discrete dipolar ion 26 can then close to a mixture of 24 and 25b. If leakage is occurring, then the amount of leakage should increase with solvent polarity which should lead to an increase in the ratio of 25b to 24. This is because 24 is formed both directly from transition state 175 and discrete dipolar ion 26 while imino ether 25b is only formed from 26. Malpass and Tweddle (22) reported that the ratio of 25b to 24 increased with solvent polarity. This change in ratio is not due to interconversion of 24 and 25b to a

thermodynamic ratio since in cases where NCS-amide and imino-lactone are known to interconvert, increasing solvent polarity, reaction time or reaction temperature is known to increase this ratio in favor of the more thermodynamically stable NCS-lactam (26).

Finally, due to some structural quirk of the olefin, closure to rearranged NCS-lactam may become the kinetically favored process. An example of this case is the addition of CSI to fenchene (169) (22).

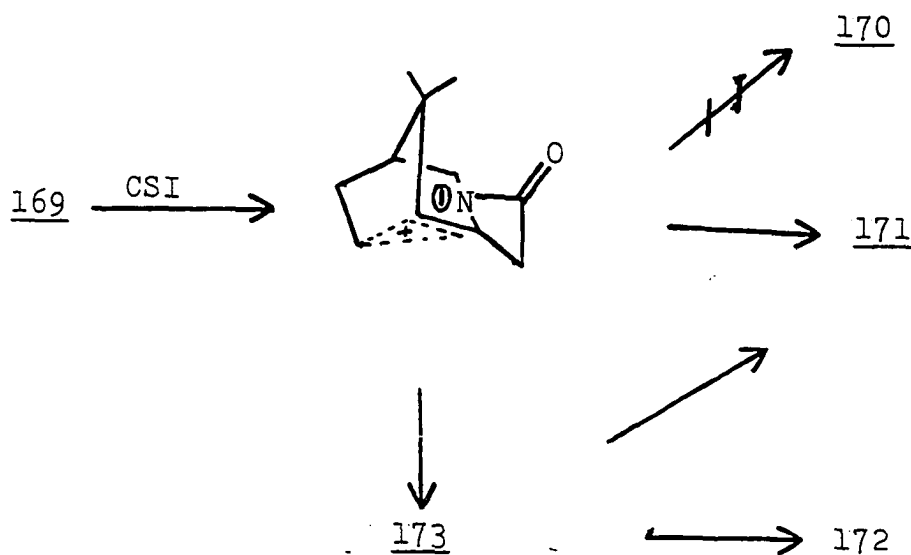

The proposed leakage pathway would account for the observation of a constant product ratio between a stable NCS- β -lactam and a rearranged imino ether if and when this pathway is observed.

EXPERIMENTAL

Infrared spectra (ir) were recorded on a Beckman 12, Beckman 18A, or a Perkin-Elmer 21 spectrophotometer and the relative intensities (s, strong; m, medium; w, weak) of significant absorptions reported. Routine nmr spectra were determined on a Varian model A-60 or a Hitachi R 20-B spectrometer, and chemical shifts were reported as parts per million (δ scale) from tetramethyl silane as an internal standard unless otherwise indicated. Decoupling and low temperature studies were recorded on the Hitachi R 20-B spectrometer. The Varian HA-100 spectrometer was used to record all 100 MHz spectra. Routine mass spectra were obtained on an Atlas CH-4 spectrometer. High resolution mass spectra were recorded on a MS-902 mass spectrometer manufactured by AEI. All melting points were obtained on a Thomas-Hoover capillary melting point apparatus and are uncorrected. Elemental analyses were performed by Ilse Beetz Mikroanalytisches Laboratorium, Kronach, West Germany.

Solvents used for CSI additions were dried by standard procedures. Chloroform was passed through basic alumina to remove ethanol.

Reactions of CSI with Cyclopropenes

Reaction of 1,3,3-trimethylcyclopropene (61) with CSI

To a magnetically stirred solution of 1,3,3-trimethylcyclopropene (61) (66) (2.73 g, 33.3 mmol) in 20 ml of dry ether cooled in a Dry-Ice/isopropanol bath was added chlorosulfonyl isocyanate (4.7 g, 33 mmol). The resulting solution was maintained at -70° for 8 hr and stirred at room temperature for 3 hr. Ether was removed under a stream of nitrogen to yield a dark, tarry mass. Several recrystallizations from methylene chloride-hexane resulted in unstable white solid 63 (1.10 g, 15%): mp $93-96^{\circ}$; nmr (CDCl_3) δ 1.97 (s, 3H), 2.40 (s, 3H), 5.39 (s, 1H), 5.67 (s, 1H), 6.06 (s, 1H), 9.05 ppm (broad, 1H); ir (KBr) 3390 (m, N-H), 1678 (s, C=O), 1460 (s, SO_2 asym) 1156 cm^{-1} (s, SO_2 sym); mass spectrum m/e 223 (p^+), 225 (p^++2 , 39% of p^+), 187 ($p^+-\text{HCl}$) and 124 ($p^+-\text{SO}_2\text{Cl}$); high resolution mass spectrum calculated for $\text{C}_7\text{H}_{10}\text{ClNO}_3\text{S}$: $m/e = 223.0070$. Found: 223.0068.

Reaction of 1-methylcyclopropene with excess CSI

1-Methylcyclopropene (42) generated by reaction of methallyl chloride and sodium amide was passed through 1N H_2SO_4 and a drying tube into a 100 ml 3-neck flask fitted with a Dry-Ice condenser, gas inlet tube and drying tube containing a solution of CSI (4.24 g, 30 mmol) in ether (ca. 30 ml). The reaction mixture was maintained at 0°

and methylcyclopropene bubbled through until the CSI was completely consumed (ca. 1 hr). The ice bath was removed, the reaction mixture stirred for an additional 2 hr and the solvent removed with a nitrogen stream. The resulting viscous oil was taken up in chloroform and hexane added which gave pure 68: mp 121-121.5°; nmr (CDCl₃) δ 1.88 (m, 3H), 5.19 (s, 1H), 5.44 ppm (apparent t, 2H); ir (KBr) 3400 (broad, N-H), 1760 (s) and 1730 (s, C=O), 1900 (s, SO₂ asym), 1430 cm⁻¹ (s, SO₂ sym); mass spectrum (70 eV) m/e (rel intensity) 336 (p⁺, 100%), 338 (p⁺+2, 74%), 340 (p⁺+4, 19%).

Anal. Calcd. for C₆H₆Cl₂N₂O₆S₂: C, 21.37; H, 1.79; S, 19.11. Found: C, 21.40; H, 1.79; S, 19.11.

Reaction of 1-methylcyclopropene with CSI

Pure 1-methylcyclopropene (41) (5.32 g, 98.4 mmol) was condensed into a 50 ml 3-neck flask (fitted with a Dry-Ice condenser, thermometer and rubber septum) containing anhydrous ether (ca. 20 ml). The resulting solution was cooled to -50° and a solution of CSI (12.71 g, 90.0 mmol) in 25 ml of ether added at a rate such that the reaction temperature never exceeded -30°. Immediate precipitation of a white solid was observed during the addition. The reaction mixture was maintained at -50° for 10 hr and slowly warmed to room temperature during which time oiling of the white solid and development of yellow coloration was observed. White solid 68, which was again precipitated,

was filtered and combined with the second crop, collected by further concentration of the ether solution. Recrystallization from chloroform-hexane gave 68 (3.19 g, 21%): mp 121-122.5°.

Attempted low temperature reduction of 1-methylcyclopropene
CSI reaction mixture

A solution of 1-methylcyclopropene (1.13 g, 21 mmol) in 25 ml of ether was prepared at -78°. To this magnetically stirred and cooled (Dry-Ice/isopropanol bath) solution CSI (2.9 g, 21.0 mmol) was added dropwise. A white solid was observed precipitating a short time after completion of the addition. The solution was stirred at ca. -78° to -60° for 1 hr at which time thiophenol (4.20 g, 42 mmol) was added. During this addition some warming was observed ($\sim 15^\circ$). The reaction mixture was warmed to -40° and a solution of pyridine (1.66 g, 21 mmol) and ether (6 ml) added over a 1 hr period. Temperature was maintained between -35° and -40° throughout the addition and for an additional 2 hr. The reaction mixture was warmed to room temperature and the ether soluble material [nmr (ether) very large aromatic peaks, ether peaks and small residual peaks at δ 5.25-4.80, 2.35-1.50 and 1.20-0.35 ppm (spinning side band of ether peak)] chromatographed on a short column packed with magnesium trisilicate. The column was eluted with hexane to remove thiophenol and diphenyl disulfide. The column was

then flushed with acetone to afford an acetone immisible brown oil which could not be further characterized from its ir and nmr spectra.

1-Methylcyclopropene-CSI low temperature nmr experiment

To a solution of 1-methylcyclopropene (0.60 g, 11.1 mmol) in dimethyl ether (3 ml), cooled in a methylene chloride slush bath (ca. -95°), was added CSI (1.56 g, 11.1 mmol) slowly with stirring. From this solution 0.5 ml samples were taken and placed in precooled nmr tubes which were introduced into a precooled nmr probe at either -60° or -70° . Two runs were made with similar results. The results from run II are reported in Table 2.

Reactions of CSI with Heterocyclopentadienes

Reaction of 1-methylpyrrole (77c) with CSI

A solution of CSI (7.10 g, 50.0 mmol) in ether (10 ml) was added dropwise to a cooled solution (-76°) of 1-methylpyrrole (76c) (4.06 g, 50.0 mmol) dissolved in ether (20 ml). Removal of the cooling bath after 1 hr caused gentle refluxing to occur. After spontaneous refluxing ceased, the reaction mixture was heated at reflux for 2 hr to insure complete reaction. Removal of ether in vacuo gave a viscous oil which spontaneously crystallized. Recrystallization from chloroform-hexane gave unstable white solid 77c (5.78 g, 52%): nmr (CDCl_3) δ 3.92 (s, 3H), 6.85-7.15 (m, 2H), 6.17

(m, 1H), 9.13 ppm (broad, 1H); ir (KBr) 1667 (s, C=O), 1439 (s, SO₂ asym) 1176 cm⁻¹ (s, SO₂ sym).

Reduction of 1-methyl-2-NCS-carboxamidopyrrole (77c)

To a solution of 1-methylpyrrole (8.12 g, 100 mmol) and ether (40 ml) was added a solution of CSI (14.20 g, 100 mmol) and ether (10 ml) dropwise. Vigorous refluxing occurred throughout the addition. The reaction mixture was stirred for 30 min after refluxing ceased. Ether was removed in vacuo which gave 77c as a light tan solid which was taken up in acetone (30 ml) and added dropwise to water (30 ml) with simultaneous addition of 2N sodium hydroxide to maintain pH between 4 and 8. The water was removed in vacuo which gave a tan solid mass which was washed with hot acetone (3 x 250 ml). Removal of acetone gave 78 as a tan solid (4.16 g, 34%). Recrystallization from chloroform gave pure 78: mp 95-96°; nmr (CDCl₃) δ 3.84 (s, 3H), 5.98 (m, 1H), 6.17 (broad, 2H), 6.60 ppm (m, 2H); ir (KBr) 3378 (m, NH₂), 1637 (s, C=O), 1603 cm⁻¹ (s); mass spectrum (12 eV) m/e 124 (only peak); high resolution mass spectrum calculated for C₆H₈N₂O: m/e = 124.0637. Found: 124.0636.

Hydrolysis of 1-methyl-2-carboxamidopyrrole (78)

Solid 78 (2.00 g, 16.1 mmol) was added to 20% potassium hydroxide (40 ml). This mixture was refluxed for 5 hr, cooled to room temperature and concentrated hydrochloric

acid added until pH 4 was obtained. The white precipitate was filtered, washed with cold water and dried under vacuum which gave white solid 79 (1.67 g, 83%). Sublimation [90° (0.3 mm)] followed by recrystallization from chloroform gave pure 79: mp 133-134° [lit. (44) mp 134-135°]; nmr (CDCl₃) δ 3.91 (s, 3H), 6.14 (m, 1H), 6.82 (m, 1H), 7.13 (m, 1H), 12.59 ppm (s, 1H); mass spectrum m/e (70 eV) (rel intensity) 125 (100%), 98 (76%), 70 (34%), 53 (39%); high resolution mass spectrum calculated for C₅H₇NO₂: m/e = 125.04771. Found: 125.0478.

Reaction of 2,5-dimethylfuran (81a) with CSI

To a solution of 81a (2.39 g, 8.25 mmol) in ether (15 ml) cooled to 0° was added CSI (3.48 g, 8.25 mmol) dropwise. After 1 hr the cooling bath was removed and the reaction mixture stirred at room temperature for an additional 4 hr. Removal of ether in vacuo gave a dark oil which spontaneously crystallized. Recrystallization from chloroform-hexane gave white solid NCS-amide 83a (2.56 g, 43%): mp (103-104.5°); nmr (CDCl₃) δ 2.24 (s, 3H), 2.58 (s, 3H), 6.35 (s, 1H), 9.42 ppm (broad, 1H); ir (KBr) 3077 (m), 1667 (s, C=O), 1563 (s), 1435 (s, SO₂ asym), 1166 (s, SO₂ sym), 1038 cm⁻¹ (s); ir (CHCl₃) 1722 cm⁻¹ (s, C=O).

Hydrolysis of 2,5-dimethyl-3-NCS-furamide (83a)

To a solution of 2,5-dimethylfuran 81a (4.80 g, 50 mmol)

and ether (30 ml) cooled to 0° was added CSI (6.95 g, 49 mmol). The reaction mixture was stirred for 4 hr (0°), warmed to room temperature and the ether removed in vacuo which gave a white solid. The solid was dissolved in a minimum amount of acetone and added to water (50 ml) with simultaneous addition of 4N sodium hydroxide in order to maintain pH between 4 and 8. After removal of acetone and water in vacuo the resulting solid was washed with several portions of hot ethanol and the washings combined, cooled, filtered, and reduced in volume. Addition of ether resulted in precipitation of 84a (2.56 g, 35%); mp (125-127°) [lit. (46) mp 125°]; nmr (D₂O, Tiers salt) δ 2.23 (s, 3H), 2.46 (s, 3H), 6.21 ppm (s, 1H); ir (KBr) 3356 (m, N-H), 3175 (m), 1667 (s, C=O), 1610 cm⁻¹ (s, amide II).

Reaction of 2,5-dimethylfuran (81a) with CSI at prolonged reduced temperature

To a solution of 81a (3.00 g, 31.2 mmol) and ether (50 ml) cooled to 0°, was added CSI (4.42 g, 31.2 mmol). Immediately after addition was complete, the reaction flask was placed into a freezer (-10°) for 3.5 days. At this time an ir of the reaction mixture showed an intense absorption at 1727 cm⁻¹ as the only peak in the carbonyl region.

The reaction mixture was placed in an ice bath and triethyl amine (6.30 g, 62.4 mmol) added slowly. Precipitation

of white solid was observed during the addition. The resulting mixture was stirred for 1 hr at room temperature, filtered to remove the solid matter, and washed with 3N HCL (20 ml), saturated sodium bicarbonate (20 ml) and saturated sodium chloride solution (20 ml). The resulting solution was dried (calcium chloride) and ether removed in vacuo which gave a tan liquid. Distillation of the liquid bp 96° (36 mm) gave 2,5-dimethyl-3-cyanofuran (1.71 g, 45%) as a colorless liquid: nmr (CCl₄) δ 6.09 (s, 1H), 2.39 (s, 3H), 2.23 ppm (s, 3H); ir (film) 3120 (w), 2960 (w), 2920 (w), 2220 (s, C≡N), 1611 (w), 1580 (s), 1250 (s), 1110 (m), 1003 (m), 986 (m), 921 (m), 792 cm⁻¹ (m); high resolution mass spectrum calculated for C₇H₇NO: m/e = 121.0528. Found: 121.0522.

Infrared study of CSI and 2,5-dimethylfuran (81a)

CSI (0.59 g, 4.17 mmol) was added dropwise to a solution of 81a (0.40 g, 4.17 mmol) in ether. Samples were taken at various times and the ir of the carbonyl region taken. The results appear in Table 2.

Attempted low temperature reduction of 2,5-dimethylfuran (81a)/CSI reaction mixture

A solution of 81a (3.20 g, 33.3 mmol) in ether was cooled to -78° and CSI (4.70 g, 33.3 mmol) added. After several hours the reaction mixture was warmed to -30° and

thiophenol (6.67 g, 66.7 mmol) added. A solution of pyridine (2.64 g, 33.4 mmol) in ether was added slowly. After 1 hr ether was removed in vacuo. An nmr of the residue revealed the presence of pyridine, aromatic protons, dimethylfuran and residual ether.

Reaction of 1,2,5-trimethylpyrrole (81c) and CSI

A solution of CSI (2.50 g, 1.77 mmol) in ether (10 ml) was added dropwise to a solution of 81c (2.18 g, 2.00 mmol) and ether (25 ml) maintained at -77° . Reaction was instantaneous with light tan solid forming with each additional drop of CSI. Five minutes after addition was complete, the reaction mixture was slowly warmed to room temperature and the reaction mixture filtered rapidly to yield 83c as a tan solid; mp $117-119^{\circ}$ w/dec. Solid 83c was unstable to standing or dissolution forming a dark orange polymeric material. The nmr spectrum was a function of solvent and time in solution: nmr (deuteroacetone) δ 3.46 (s, 1), 2.50 (s, 1), 2.1, 2.17 ppm (s, 167), (no peaks at lower field than δ 3.46); nmr (CDCl_3) δ 6.08 (s, 1H), 3.43 (s, 3.5H), 2.56 (s, 3H), 2.20 (s, 3H); ir (KBr) 3077 (m, N-H), 1664 (s, C=O), 1441 (s, SO_2 asym), 1183 (s, SO_2 sym).

The remaining solid (slightly orange and oily) was dissolved in acetone (turned dark orange) and the solution added to water as rapidly as possible with simultaneous addition of 2N NaOH in order to maintain the pH between 4

and 8. The water and acetone were removed in vacuo and the residue washed with several portions of hot ethanol. The ethanol washings were cooled and precipitated Na_2SO_4 , (H_2O) x filtered. The filtrate was concentrated and ether added which precipitated a small amount of white solid (84c): mp 188-189.5° w/dec.; nmr (D_2O , Tiers salt) δ 6.11 (s, 1H), 3.32 (s, 3H), 2.38 (s, 3H), 2.11 ppm (s, 3H); ir 3484 and 3311 (m, N-H), 1642 (s, C=O), 1567 cm^{-1} (m, amide II). Since only incomplete data was available and the proposed structure inconclusively proven, this reaction was repeated but no 84c isolated. In an attempt to obtain a characterizable amount, the following reaction was run.

To a mechanically stirred solution of 81c (2.18 g, 20.0 mmol) CSI (2.82 g, 20.0 mmol) was added over a 10 min period. After an additional 20 min thiophenol (4.00 g, 40.0 mmol) was added dropwise. The reaction mixture was warmed to -40° followed by addition of a solution of pyridine (1.74 g, 22.0 mmol) and ether (10 ml) at a rate such that the reaction temperature never exceeded -30° . The reaction mixture was stirred for an additional 30 min and slowly warmed to room temperature. Additional ether (50 ml) was added, the precipitate filtered, dissolved in warm water, the water solution cooled and extracted with methylene chloride (3 x 75 ml), the methylene chloride extracts were combined and dried over calcium chloride and solvent removed

to give a gummy solid. The nmr spectrum showed this solid to be a mixture of pyridine, 84c, and smaller amounts of other impurities.

Evaporation of ether from the filtrate gave a yellow oil; nmr: diphenyl disulfide and 6.08 (m, 2), 5.89 (s, 5), 5.71 (s, 4), 3.33 (s, 13), 3.18 (s, 7), 3.09 (s, 13), 2.11 (s), and 2.08 (s, 24), 1.89 ppm (s, 13). Chromatography on Florosil led to recovery of only diphenyl disulfide.

Reaction of 2,5-dimethylthiophene (81b) with CSI

To a solution of 81b (2.24 g, 20.0 mmol) in ether (25 ml) cooled in a Dry-Ice/acetone bath, CSI (2.80 g, 20.0 mmol) was added. The reaction mixture was warmed to room temperature and stirred for several hours. An nmr at this time showed that very little reaction had taken place. However, a new peak at δ 6.89 ppm was observed. Removal of ether resulted in a dark tarry mass. An nmr showed that the δ 6.89 ppm peak had grown relative to starting material. The tarry mass was dissolved in chloroform and hexane added which precipitated a small amount of solid. Recrystallization from chloroform/hexane gave white solid 83b: mp 117-120° w/dec; nmr (CDCl₃) δ 8.90 (broad, 1H), 6.89 (s, 1H), 2.70 (s, 3H), 2.43 ppm (s, 3H); ir (KBr) 3175 (m, N-H), 1678 (s, C=O), 1439 (s, SO₂ asym), 1189 (s, SO₂ sym).

Reaction of 2,5-dimethylthiophene (81b) with CSI in acetonitrile

CSI (1.41 g, 10.0 mmol) was added to a solution of (81b) (1.12 g, 10.0 mmol) and acetonitrile (8 ml). Shortly after addition the reaction mixture had acquired a dark coloration. An nmr spectrum taken after 11 hr revealed besides the acetonitrile peak: δ 6.94 (s), 2.66 (s), 2.40 (s), ca. 1:3:3 ratio. Attempted work up led to severe darkening and recovery of a black polymeric gum.

In situ reduction of NCS amide 83b

CSI (2.41 g, 17.0 mmol) was added to a solution of 2,5-dimethylthiophene (1.91 g, 17.0 mmol) and acetonitrile cooled to 0°. After the addition was complete the reaction mixture was stirred at room temperature for 11 hr. The reaction mixture was then added to water (25 ml) with periodic additions of 2N sodium hydroxide, to regulate the pH between 5 and 8, and ice to keep the reaction temperature below 25°. The reaction mixture was acidified to pH2 by addition of 3N HCl and continuously extracted with ether for 3 days. The extracted material was recrystallized from acetone-hexane which gave 84b (0.32 g, 12%): mp 131.5-134° [lit. (67) mp 135°]; nmr (deuteroacetone) δ 6.89 (s) and 7.2-6.3 (broad) (combined 2H), 2.59 (s, 3H), 2.32 ppm (s, 3H); ir (KBr) 3370 (N-H), 3190; 1650 (amide I), 1620 (amide II), 1505, 1408 cm^{-1} ; mass spectrum (20 eV) m/e 155 (p^+)

(only peak); high resolution mass spectrum calculated for C_7H_9NOS : $m/e = 155.0405$. Found: 155.0397.

Reaction of 1,2,5-triphenylphosphole (88) with CSI

CSI (0.57 g, 4.03 mmol) was added to a solution of 88 (68) (1.01 g, 3.23 mmol) and chloroform (25 ml). Shortly after addition was completed, the reaction mixture was refluxed for 1 hr, solvent removed in vacuo, and the resulting yellow solid washed with small portions of hot acetone which gave 1,2,5-triphenylphosphole oxide (89) (0.81 g, 79%): mp 232-235° [lit. (I) mp 237-239°]; ir (KBr) 1141 (m, P-Ph), 1179 (s, P=O), 1105 (P=Ph).

Reaction of 1,1-dimethyl-2,5-diphenyl-silole (90) and CSI in ether

CSI (0.85 g, 6.0 mmol) was added to a stirred solution of silole 90 (69,70) and ether (20 ml). The reaction mixture was stirred at room temperature for 12 hr during which time (103) had precipitated as a bright yellow solid. The reaction mixture was filtered and the collected solid re-crystallized from methylene chloride-ether to give 103 (1.03 g, 43%) as yellow needles: mp 140-142° w/dec; nmr ($CDCl_3$) δ 7.50-7.01 (m, 12H), 0.65 ppm (s, 6H); ir (KBr) 1582 (m-w), 1541 (m), 1506 (s), 1441 (m-w), 1399 (m), 1359 (s), 1312 (m), 1256 (m), 1167 (s), 1153 (m), 1006 (m), 931 (m-w), 866 (m), 750 (s), 696 (s).

Anal. Calcd. for $C_{19}H_{18}ClNO_3SiS$: C, 56.50; H, 4.49; N, 3.47. Found: C, 56.59; H, 4.20; N, 3.70.

Reactions of CSI with trans- β -Trimethylsilylstyrene

Reaction of trans- β -trimethylsilylstyrene 105 with CSI and acid workup

CSI (1.66 g, 11.7 mmol) was added to a solution of 105 (71) (2.00 g, 11.3 mmol) in carbon tetrachloride (10 ml) cooled to 0°. After 0.5 hr, the ice bath was removed and the solution stirred for an additional hour at room temperature. Carbon tetrachloride was removed under vacuum, the residual oil dissolved in acetone and 0.1N hydrochloric acid (1.6 ml) added. The reaction mixture spontaneously refluxed for 5 min. Water (10 ml) was added, the resulting mixture extracted with ether (150 ml), the ether layer separated and dried (sodium sulfate), and ether removed under vacuum which gave an oily white solid. Recrystallization from chloroform-cyclohexane gave trans-cinnamamide (108) (1.05 g, 63%): mp 146-148° [lit. (72) mp 148-148.5°]; nmr ($CDCl_3$) δ 7.67 (d, $J = 16$ Hz) and 7.80-7.28 (m) (combined 6H), 6.46 (d, 1H, $J = 16$ Hz), 5.90 ppm (broad, 2H); mass spectrum (70 eV) m/e 147 (p^+). The ir spectrum corresponded exactly with an authentic spectrum of 108 (73). Solvent was removed under vacuum from the mother liquor which gave trans-cinnamitrile (109) (0.17 g, 1%): nmr ($CDCl_3$) δ 7.40 (s)

and 7.36 (d, $J = 17$ Hz) (combined 6H), 5.82 ppm (d, 1H, $J = 17$ Hz); mass spectrum (70 eV) m/e 129 (p^+). The ir spectrum corresponded exactly with an authentic spectrum of 24 (73, p. 128).

Reaction of trans- β -trimethylsilylstyrene (105) with CSI

A solution of 105 (2.00 g, 11.3 mmol) and carbon tetrachloride (10 ml) was cooled to 0° and CSI (1.66 g, 11.7 mmol) added. After 1.0 hr, the reaction mixture was warmed to room temperature at which time the ir spectrum showed the absence of CSI and: 2960 [m, Si (CH₃)₃], 1628 (s, C=C), 1540 (s, C=N), 1450 (m-s, Si-C), 1380 (s, SO₂ asym), 1185 cm⁻¹ (s, SO₂ sym); assigned to 106. Removal of carbon tetrachloride under vacuum gave a semisolid material (3.32 g, 92%) which when washed with hexane gave white crystalline 106: mp 72-74°; nmr (CCl₄) δ 7.93 (d, 1H, $J = 16$ Hz), 7.77-7.36 (m, 6H), 0.50 ppm (s, 9H). Exposure of 106 to moisture led to formation of NCS-amide 110.

Reaction of 106 with β -phenethyl alcohol

A solution of adduct 106 (11.3 mmol) and carbon tetrachloride was prepared in the usual way. To this a solution of β -phenethyl alcohol (1.07 g, 8.8 mmol) and carbon tetrachloride was added which led to immediate precipitation of NCS-amide 110 (2.18 g, 100%): mp 120-124°. Rapid recrystallization from acetone-hexane gave pure 110 as white

microcrystals: mp 124-125° w/dec; nmr (d₆ acetone) δ 7.82 (d, $J = 16$ Hz) and 7.65-7.20 (m) (combined 6H), 6.68 ppm (d, 1H, $J = 16$ Hz); ir (KBr) 3185 (broad, NH), 1704 (s, C=O), 1629 (s, C=C), 1456 (s, SO₂ asym), 1389 (m), 1202 (m), 1117 (s, SO₂ sym), 776 (m), 892 (m).

The filtrate was distilled at atmospheric pressure until most of the carbon tetrachloride had been removed. Vacuum distillation of the residue and collection of a middle cut gave trimethylphenethoxysilane 111 (0.68 g, 39%): bp 94° (12 mm) [lit. (74) bp 102° (18 mm)]. Further purification by gas chromatography (4 ft. x 3/8 in., 30% SE-30 on Chromosorb W, column temperature 165°, flow rate 51 cc/min, retention time 14.8 min) resulted in collection of pure 111 as a colorless liquid: nmr (CCl₄) δ 7.14 (s, 5H), 3.72 (t, 2H, $J = 7$ Hz), 2.75 (t, 2H, $J = 7$ Hz), 0.00 ppm (s, 9H); mass spectrum (70 eV) m/e (rel intensity) 194 (trace, p⁺), 179 (45%, p⁺-CH₃), 103 [74%, CH₂OSi(CH₃)₃], 73 [100%, Si(CH₃)₃].

Hydrolysis of NCS-amide 110

NCS-amide 110 (0.48 g, 1.95 mmol) was dissolved in acetone (10 ml) and water (12 ml) added. This solution was gently refluxed for 5 min followed by addition of 2N sodium hydroxide until the solution was just basic to pH paper.

Cooling the solution led to precipitation of cinnamamide (0.20 g, 70%). Recrystallization from chloroform-cyclohexane gave trans-cinnamamide (108) which was identical in every respect with the previously identified material.

Reactions of CSI with 2-Cyclopropylpropene

Addition of CSI to 2-cyclopropylpropene (114) with water and thiophenol-pyridine workup

A solution of 114 (75) (4.12 g, 50.2 mmol) and ether (10 ml) was added dropwise to a solution of CSI (6.79 g, 47.9 mmol) and ether (10 ml) maintained at 0°. The reaction mixture was stirred at 0° for 4.5 hr at which time all the CSI had reacted (no 2247 cm⁻¹ band in the ir). Water (12.5 ml) was added dropwise followed by additional ether (25 ml). The ether layer was separated, dried over magnesium sulfate and ether removed under vacuum which gave a light yellow oil (4.21 g). The oil was dissolved in acetone (3 ml), cooled to -30° and thiophenol (3.76 g, 37.6 mmol) added over 40 min while maintaining reaction temperature between -30° and -35°. The reaction mixture was stirred at these temperatures for an additional 40 min at which time water (5 ml) was added slowly. The reaction mixture was warmed to room temperature and extracted with ether (5 x 25 ml), ether extracts combined, dried over magnesium sulfate and ether removed under vacuum which gave a yellow oil. This oil was

chromatographed on a magnesium trisilicate column (2 x 12 in). Diphenyl disulfide was eluted with hexane. Elution with ether gave a mixture of 119a and 119b as a colorless oil: nmr (CDCl₃) δ 6.10 (broad, 2H), 5.35 (hashed t, 1H), 3.57 (t, 2H, J = 7 Hz), 3.00 (s) and 2.94 (s, combined 2H), 2.52 (q, 2H, J = 7 Hz), 1.81 (d, J = 1 Hz) and 1.72 ppm (s, combined 3H).

Elution with acetone and crystallization of resulting oil from chloroform-hexane gave a mixture of 119b and 120 as a white solid: mp 83-95°. The nmr spectrum of 120 was determined by subtraction of the spectrum of 119b from the spectrum of the mixture: nmr (CDCl₃) δ 6.10 (broad, N-H), 5.70 (s, 1H), 1.99 (d, 3H, J = 1.5 Hz), 1.38 (m, 1H) and 0.70 ppm (m, 4H). Crystallization had removed an impurity with the following nmr: δ 2.60 (s, 1), 2.17 (s, 1.32), 1.21 ppm (s, 2.58). A portion of the mixture 119b and 120 was subjected to preparative thick layer chromatography (20 x 20 cm plate) on silica gel PF₂₅₄ with acetone-hexane 3:2 (V/V) elution. Three bands were observed. Two bands were trace impurities while the center band essentially the same nmr spectrum as the original mixture.

Addition of CSI to 2-cyclopropylpropene (114) and sodium bicarbonate workup

CSI (4.40 g, 31.1 mmol) was added dropwise to a solution of 2-cyclopropylpropene (2.55 g, 31.05 mmol) in

ether (25 ml) cooled to 0°. The reaction mixture was stirred for 2 hr at room temperature and a saturated solution of sodium bicarbonate (10 ml) added. The resulting two phase system was stirred for an additional 2 hr which gave a three phase mixture. The ether phase was separated (top layer) and the remaining two phases extracted with chloroform. The ether phase and chloroform washings were combined, dried over magnesium sulfate and solvents removed under vacuum which gave a light yellow oil. This oil was washed with boiling ether, the ether solution concentrated and cooled to precipitate somewhat impure 119b (0.39 g) as a white solid. Several recrystallizations from hot benzene-hexane gave pure 119b: mp 113-114.5°; nmr (CDCl₃) δ 6.05 (broad, 2H, NH₂), 5.35 (t, 1H, J = 7.8 Hz), 3.57 (t, 2H, J = 7.8 Hz), 2.94 (s, 2H), 2.52 (q, 2H, J = 7.2 Hz), 1.72 ppm (s, 3H); ir (KBr) 3155 (w, N-H), 1656 (s, amide I), 1595 (m, amide II), 1399 (m), 1274 (w), 767 cm⁻¹ (w); mass spectrum m/e (70 eV) (rel intensity) 161 (trace), 126 (53%), 125 (100%), 69 (76%), metastable 97.0 (161 to 125, calculated 97.0); high resolution mass spectrum calculated for C₇H₁₁NO: m/e = 125.084. Found: 125.084; calculated for C₇H₁₂NO: m/e = 126.092. Found: 126.092.

Anal. Calcd. for C₇H₁₂ClNO: C, 52.02; H, 7.48; Cl, 21.93; N, 8.66. Found: C, 52.15; H, 7.31; Cl, 21.89; N, 8.68.

Sublimation [80°, (0.1 mm)] of the residual yellow oil gave a white solid (0.38 g) which was a mixture of 119b and 120 (by nmr).

Addition of CSI to 2-cyclopropylpropene 114 and room temperature nmr observation of the initial product mixture

Equimolar amounts of CSI and 114 were mixed in CDCl₃ solution at -78° in an nmr tube and slowly warmed to room temperature. The resulting nmr: δ 10.11 (s, 14, NH SO₂ Cl), 5.85 (m, 4), 4.88 (s, 18), 3.27 (s, 22), 1.70-0.4 ppm (m, cyclopropyl H's) was assigned to a mixture of 121 and 122. The contents of the nmr tube were shaken with saturated sodium bicarbonate solution. The deuteriochloroform layer was separated and contained only a very small amount of unreacted 121 and 122. After 3 hr, an oil separated from the sodium bicarbonate layer. Its nmr showed it to be a mixture of amides 119a, 119b and 120.

Preparation and purification of nitriles 123, 124 and 125

A solution of 114 (2.55 g, 31.5 mmol) and chloroform (15 ml) was cooled to 0°. To this, CSI (4.38 g, 30.9 mmol) was added dropwise. The reaction mixture was stirred at room temperature for 1 hr and recooled to 0°. Triethylamine (6.25 g, 61.8 mmol) was added dropwise followed by stirring at room temperature for 1 hr during which time the reaction mixture darkened. It was then washed with water (2 x 50 ml),

dried briefly over calcium chloride and chloroform removed under vacuum which gave a dark tarry mixture. Distillation gave a mixture of nitriles 123, 124 and 125 as a light yellow oil (0.86 g, 26%): bp 78° (11 mm) [lit. (50) bp 103-104° (30-32 mm)]; nmr (CCl₄) δ 5.11 (m, 20), 4.90 (s, 6), 3.09 (m, 14), 1.83 (s, 27), 1.55 (d, 26), 0.70 ppm (m, 93).

The mixture exhibited three peaks (retention time 14.2, 18.4 and 19.9 min) when subjected to gas chromatography (8 ft x 0.25 in column packed with 10% Carbowax 20 M on Chromosorb W, column temperature 137°, head pressure 22.5 psi). Collection of these peaks resulted in pure fractions of 123, 124 and 125: 123 nmr (CCl₄) δ 5.07 (m, 1H), 4.92 (broad s, 1H), 3.07 (d, 2H, $J = 1$ cps), 1.67-1.10 (m, 1H), 0.96-0.44 (m, 4H); ir (film) 3090 (w), 3010 (w), 2250 (m, CN), 1655 (m), 1418 (m), 1055 (w), 1025 (m), 900 (s), 822 cm⁻¹ (w); mass spectrum (70 eV) m/e (rel intensity) 107 (p⁺, 58%), 80 (100%), 79 (98%); high resolution mass spectrum calculated for C₇H₉N: $m/e = 107.073$. Found: 107.073; 124 nmr (CDCl₃) δ 5.10 (broad s, 1H), 1.87 (s, 3H), 1.83-1.38 (m, 1H), 1.00-0.59 ppm (m, 4H); ir (film) 3100 (w), 3020 (w), 2220 (s, CN), 1623 (s), 1445 (m), 1397 (w), 1226 (m), 1090 (w), 1058 (w), 1029 (w), 970 (m), 888 (s), 800 cm⁻¹ (m); mass spectrum (70 eV) m/e (rel intensity) 107 (p⁺, 64%), 80 (100%), 79 (100%); high resolution mass spectrum obs. $m/e = 107.073$; 125 nmr (CCl₄) δ 5.07 (m, 1H), 2.37-1.83 (m, 1H), 1.57 (d,

3H, $J = 1.5$ cps), 1.10-0.67 ppm (m, 4H); ir (film) 3095 (w), 3020 (w), 2210 (s, CN), 1612 (m), 1445 (m), 1395 (m), 1318 (w), 923 (m), 819 (w), 785 cm^{-1} (w); mass spectrum (70 eV) m/e (rel intensity) 107 (p^+ , 48%), 80 (98%), 79 (100%); high resolution mass spectrum obs. $m/e = 107.072$.

Preparation of β -lactam 128 by thiophenol-pyridine reduction

A solution of 2-cyclopropylpropene (5.35 g, 65.3 mmol) in ether (35 ml) was cooled to -78° . To this CSI (9.24 g, 65.3 mmol) was added dropwise which resulted in precipitation of a white solid. The reaction mixture was then warmed to -40° and thiophenol (13.06 g, 130 mmol) added. A solution of pyridine (5.15 g, 65.3 mmol) and ether (15 ml) was added over the period of 1 hr after which the reaction mixture was slowly warmed to room temperature. The resulting suspension was filtered and the collected solid washed with ether. The combined ether solutions were washed with water (35 ml), dried over magnesium sulfate, and the ether removed under vacuum. The resulting oil was taken up in a minimum amount of carbon tetrachloride and placed on a short magnesium trisilicate column. Elution with hexane resulted in recovery of diphenyl disulfide. Elution with acetone gave slightly impure 128 (4.34 g, 53%) as a light yellow oil. Distillation gave a colorless oil [bp 74° (.016 mm)] which crystallized upon rapid cooling to -78° . Recrystallization of the

slightly oily solid from carbon tetrachloride-hexane gave 128 as clear, colorless needles: mp 39-41°; nmr (CCl₄) δ 7.27 (broad, NH, 1H), 2.50 (d, 2H, $J = 1.5$ Hz), 1.42 (s, 3H), 1.30-0.20 ppm (m, 5H); ir (film) 3260 (3260 (m, broad, 3090 (m), 3010 (m), 2980 (m), 2930 (w), 2880 (w), 1760 (s), 1418 (m), 1379 (m), 1290 (m), 1230 (m), 1042 cm⁻¹ (m); ir (CCl₄ solution) 1768 and 1786 cm⁻¹ (s, C=O); mass spectrum (70 eV) m/e (rel intensity) 125 (2%), 124 (3%), 110 (10%), 97 (22%), 82 (47%), 68 (31%), 67 (100%).

Anal. Calcd. for C₇H₁₁NO: C, 67.17; H, 8.85; N, 11.19. Found: C, 67.32; H, 8.69; N, 11.07.

Reactions of CSI with Diphenylmethylenecyclopropane

Reaction of CSI with diphenylmethylenecyclopropane (139)

CSI (1.37 g, 97.2 mmol) was added dropwise to a solution of diphenylmethylenecyclopropane (139b) (76) (2.00 g, 97.2 mmol) and chloroform (15 ml) cooled to 0°. After the addition was completed the reaction mixture was stirred for 10 min at 0°, warmed briefly to room temperature, cooled to -40° and thiophenol (1.94 g, 194 mmol) added. A solution of pyridine (0.77 g, 97.2 mmol) and chloroform (4 ml) was added over a period of 30 min while maintaining the reaction temperature between -30° and -40°. The reaction mixture was stirred at -30° for 2 hr and warmed to room temperature. The reaction mixture was concentrated under vacuum and

chromatographed on a short magnesium trisilicate column. The column was flushed with hexane until no more diphenyl disulfide eluted. The column was then eluted with chloroform-hexane (60:40, V:V) which gave 145 as a colorless oil. Crystallization from methylene chloride-hexane gave pure 145 (1.10 g, 45%): mp 168-170°; nmr (CDCl₃) δ 7.21 (s with broad base, 11H), 1.26 (m, 2H), 0.91 ppm (m, 2H); ir (KBr) 3150 (m, broad, N-H), 1750 and 1718 (s, C=O), 1499 (m), 1452 (m), 1010 (m), 990 (m), 761 (s), 712 cm⁻¹ (s); ir (CHCl₃) 1767 cm⁻¹ (s, CO); mass spectrum (70 eV) m/e (rel intensity) 249 (100%), 248 (67%); mass spectrum (16 eV) (rel intensity) 249 (100%), 248 (25%); high resolution mass spectrum calculated for C₁₇H₁₅NO: m/e = 249.1154. Found: 249.1152; calculated for C₁₇H₁₄NO: m/e = 248.1075. Found: 248.1096.

Nmr investigation of the reaction of CSI with diphenylene-cyclopropane 137b

Diphenylmethylenecyclopropane (0.10 g, 0.49 mmol) was dissolved in deuteriochloroform, the resulting solution was placed in an nmr tube and cooled to 0°. CSI (0.069 g, 0.49 mmol) was added rapidly and the tube shaken and recooled to 0°. Warming (probe temperature) and taking the nmr spectrum as rapidly as possible gave the following nmr: δ 7.33 (s, 10H), 1.60 (m, 2H); 1.10 ppm (m, 2H) (multiplet

at 1.60 and 1.10 are mirror images of one another). An ir (CDCl_3) showed an absorption at 1828 cm^{-1} as the only absorption in the carbonyl region. After 24 hr at room temperature only the nmr absorptions previously reported for 141 (58) were observed.

Reactions of CSI with Cyclobutenes

Attempted reaction of CSI with cyclobutene

An nmr tube containing deuteriochloroform (0.2 ml) CSI (0.28 g, 2.04 mmol) and cyclobutene (77) (0.11 g, 2.04 mmol) was prepared and sealed at -78° . Nmr spectra were recorded after standing overnight at room temperature, 4 hr at 50° and 2 hr at 90° and exhibited only the spectrum of cyclobutene. After heating for an addition 9 hr at 90° some reaction had taken place as determined by nmr.

Attempted reactions of CSI and 3,3-dimethylcyclobutene

A solution of CSI (0.17 g, 1.22 mmol) and sufficient deuteriochloroform to give a total volume of 0.2 ml was added to a solution of 3,3-dimethylcyclobutene¹ (0.10 g, 1.22 mmol) contained in an nmr tube. Nmr spectra recorded immediately after addition and after 23 hr at room temperature exhibited only the spectrum of 3,3-dimethylcyclobutene.

¹Supplied by Dr. R. Roth, Iowa State University, 1972.

After four days at room temperature some reactions had taken place as determined by nmr.

To a solution of 3,3-dimethylcyclobutene (0.10 g, 1.22 mmol), deuterionitromethane (0.2 ml) and deuteriochloroform (0.1 ml) was added CSI (0.17 g, 1.22 mmol). An nmr spectrum recorded immediately after addition exhibited only the spectrum of 3,3-dimethylcyclobutene. Heating for 5 hr at 80° caused some reaction to occur but the major component was still starting material as determined by nmr.

Preparation of NCS- β -lactam 157a

To a solution of 1,2-dimethylcyclobutene (78) (3.28 g, 40.0 mmol) and ether (15 ml) cooled to -78°, a solution of CSI (5.68 g, 40.0 mmol) and ether (10 ml) was added over a 10 min period. The reaction mixture was stirred at -78° for 10 hr and room temperature for 2 hr. Ether was removed under vacuum, the light yellow oil taken up in chloroform and passed through a short silica gel column which gave pure NCS- β -lactam 157a (5.15 g, 57%): mp 57-59°; nmr (CCl₄) δ 2.92-2.02 (m, 4H), 1.60 (2, 3H), 1.33 ppm (s, 3H); ir (CCl₄) 1818 (s, C=O), 1408 (s, SO₂ asym), 1166 cm⁻¹ (s, SO₂ sym); mass spectrum m/e (70 eV) (rel intensity) 225 [<1%, (41% of 223)], 223 (<1%), 160 (5%), 132 (4%), 124 (31%), 96 (100%).

Anal. Calcd. for $C_7H_{10}ClNO_3S$: C, 37.59; H, 4.51; N, 6.26; Cl, 15.85. Found: C, 37.65; H, 4.60; N, 6.21; Cl, 15.89.

Reduction of NCS- β -lactam 157a

A solution of NCS- β -lactam 157a (2.24 g, 10.0 mmol) in acetone (25 ml) was cooled to -30° and thiophenol (2.11 g, 20.0 mmol) added. A solution of pyridine (0.95 g, 12.0 mmol) and acetone (1.5 ml) was added slowly while maintaining the reaction temperature at -30° . After stirring for an additional 30 min at this temperature, water (4 ml) was dropwise. After warming to room temperature the precipitated diphenyl disulfide was filtered and the resulting aqueous solution extracted with ether (6 x 5 ml). The extracts were combined, dried over sodium sulfate and ether removed under vacuum which gave a colorless oil that crystallized upon standing. Recrystallization from chloroform-hexane gave pure β -lactam 157b (0.41 g, 33%): mp $74-74.5^\circ$; nmr (CCl_4) δ 7.65 (broad, 1H), 2.30-1.65 (m, 4H), 1.30 (s, 3H), 1.15 ppm (s, 3H); nmr ($CDCl_3$) δ 6.90 (broad, 1H), 2.20-1.70 (m, 4H), 1.31 (s, 3H), 1.21 ppm (s, 3H); ir (KBr) 3165 (m-s, N-H), 2941 (m), 1733 (s, C=O), 1695 cm^{-1} (s, C=O); ir (CCl_4) 1767 and 1745 cm^{-1} (s, C=O); mass spectrum m/e (70 eV) (rel intensity) 125 (100%), 110 (34%), 97 (16%), 96 (32%), 82 (74%), 70 (36%), metastable 70.0 (125 to 110 calcd. 70.0).

Anal. Calcd. for $C_7H_{11}NO$: C, 67.17; H, 8.86; N, 11.19.
Found: C, 67.34; H, 8.76; N, 11.09.

β -lactam 157b could also be prepared directly, without isolation of NCS- β -lactam 157a, in 26% overall yield.

Reaction of CSI with 1-methylcyclobutene

A solution of CSI (1.75 g, 12.4 mmol) and ether (8 ml) was added to a magnetically stirred solution of 1-methylcyclobutene (79) (1.00 g, 14.7 mmol) and ether (3 ml) cooled to 0° . The reaction mixture was stirred at 0° for 1 hr and at room temperature for an additional hour. An ir spectrum taken at this time exhibited a carbonyl band at 1825 cm^{-1} and two other bands at 1750 and 1720 cm^{-1} of much lower intensity. Removal of ether under a stream of nitrogen gave a light yellow oil which was dissolved in acetone (5 ml) and added to a solution of acetone (5 ml) and water (10 ml). Periodic additions of 4N potassium hydroxide were made in order to maintain the pH between 5 and 8. The resulting aqueous solution was extracted with methylene chloride (4 x 50 ml), the extracts combined, dried over calcium chloride and the solvent removed under vacuum which gave a light yellow oil (0.50 g, 36%). A portion of this oil was distilled [molecular, 40° (.002 mm)] which gave β -lactam 159b as a clear colorless oil: nmr (CCl_4) δ 7.75 (broad, 1H), 3.23 (m, 1H), 2.60-1.80 (m, 4H), 1.43 ppm

(s, 3H); ir (film) 3260 (m, N-H), 2950 (m), 2865 (w), 1742 cm^{-1} (s, C=O); ir (CCl_4) 1770 and 1755 cm^{-1} (s, C=O); mass spectrum $\underline{m/e}$ (70 eV) (rel intensity) 112 (2%), 111 (5%), 96 (6%), 83 (100%), 68 (21%), 67 (12%); mass spectrum $\underline{m/e}$ (16 eV) (rel intensity) 112 (5%), 111 (35%), 96 (30%), 83 (100%), 68 (10%); high resolution mass spectrum calculated for $\text{C}_6\text{H}_8\text{O}_2$: $\underline{m/e} = 112.0524$. Found: 125.092; calculated for $\text{C}_6\text{H}_{10}\text{NO}$: $\underline{m/e} = 112.0762$. Found: 112.0763; calculated for $\text{C}_6\text{H}_9\text{NO}$: $\underline{m/e} = 111.0684$. Found: 111.0679.

The amount of impurity was variable from reaction to reaction and was minimized by use of methylene chloride as the reaction solvent and keeping the reaction mixture at 0° until reduction was complete.

From other runs NCS- β -lactam 159a was characterized to the following extent: nmr (CCl_4) δ 3.62 (m, 1H), 3.05-2.15 (m, 4H), 1.73 ppm (s, 3H); ir (film) 1812 cm^{-1} (C=O).

Reaction of CSI with methylenecyclobutane

CSI (4.00 g, 28.3 mmol) was added to a stirred solution of methylenecyclobutane (2.00 g, 29.4 mmol) and methylene chloride (15 ml) maintained at 0° . After 30 min the reaction mixture was warmed to room temperature and stirred for an additional 30 min. Removal of the solvent gave an oil which was taken up in acetone (4 ml) and added rapidly in portions to a solution of water (10 ml) and acetone

(5 ml) with simultaneous additions of 4N potassium hydroxide in order to maintain the pH between 5 and 8. The precipitated hydrated sodium sulfate was filtered, the resulting solution extracted with methylene chloride (4 x 50 ml), the extracts combined and dried (calcium chloride), and solvent removed in vacuo which gave slightly impure β -lactam 160b (1.30 g, 41%) as an oil. The oil was distilled [bp 64° (0.3 mm)] and the distillate crystallized from the methylene chloride-hexane at -78°: nmr (CCl₄) δ 7.60 (broad, 1H), 2.80 (d, 2H, $J = 2$ Hz), 2.75-1.35 ppm (m, 6H); ir (film) 3270 (m, N-H), 2980 (m), 2945 (m), 1750 (s, broad), 1385 (m), 1295 (m), 1110 cm⁻¹ (m); ir (CCl₄) 1775 and 1769 cm⁻¹ (s, C=O); mass spectrum m/e (70 eV) (rel intensity) 111 (3%), 83 (100%), 68 (15%), 67 (14%); high resolution mass spectrum calculated for C₆H₉NO: m/e = 111.0684. Found: 111.0681.

Reinvestigation of the 1,1-Dimethyl-2,5-
diphenylsilole-CSI Reaction

Nmr observation of the CSI-1,1-dimethyl-2,5-diphenylsilole
90 (A,B) in deuteriochloroform

A solution of silole 90 (100 mg, 3.81 mmol) and deuteriochloroform (0.3 ml) contained in an nmr tube was cooled to 0°. To this a solution of deuteriochloroform (0.1 ml) and CSI (54 mg, 3.81 mmol) was added slowly with periodic shaking. Immediately upon addition, the solution

exhibited a bright green color which slowly turned a brown-red color.

After warming to room temperature, the nmr spectrum exhibited aromatic H's and the following absorption assigned to NCS- β -lactam 91: δ 7.31 (d, 1H, $J = 4$ Hz), 5.44 (d, 1H, $J = 4$ Hz), 0.58 (s, 3H), 0.00 ppm (s, 3H); along with a small singlet at δ 0.62 ppm assigned to imino lactam 103. Examination of the nmr spectrum after 20 min showed no noticeable change. After 5 hr the δ 0.62 ppm singlet had increased in intensity relative to those at δ 0.58 and 0.00 ppm.

After standing overnight, bright yellow needles had precipitated. Filtration of the solution gave 103: ir (KBr) 1590 (m), 1549 (m), 1510 (s), 1450 (m), 1405 (m-s), 1362 (s), 1319 (m), 1262 (m-s), 1172 (s), 1160 (m), 1005 (m), 936 cm^{-1} (m-w).

Low temperature reduction of NCS- β -lactam 91

A solution of silole 90 (2.00 g, 7.62 mmol) and chloroform (14 ml) was cooled to 0°. To this CSI (1.08 g, 7.62 mmol) was added rapidly followed by removal of the cooling bath. After 2 hr an ir spectrum indicated all the CSI had reacted and exhibited only a band at 1812 cm^{-1} in the carbonyl region. The reaction mixture was cooled to -40° and thiophenol added (1.52 g, 15.2 mmol) followed by

addition of a solution of pyridine (0.60 g, 7.62 mmol) and chloroform (4 ml) during a 0.5 hr period. The reaction mixture was slowly warmed to room temperature (ca. 4 hr), poured into chloroform (100 ml) and washed successively with 50 ml portions of saturated ammonium chloride, 10% sodium carbonate, water and saturated sodium chloride. The organic layer was dried (calcium chloride) and chloroform removed under vacuum which gave a yellow oil which spontaneously crystallized. The resulting solid was washed with several portions of hot hexane which removed most of the diphenylsulfide. The remaining solid was taken up in acetone, undissolved inorganic impurities removed by filtration, acetone removed under vacuum and the resulting solid recrystallized from chloroform-hexane which gave β -lactam 161 as a white solid (0.99 g, 43%). Further recrystallization gave pure 161: mp 179-181°; nmr (CDCl₃) δ 7.37 (m, 10H); 7.25 (broad, 1H), 7.08 (d, 1H, $J = 2.9$ Hz), 4.69 (d, 1H, $J = 2.9$ Hz), 0.55 (s, 3H), -0.04 ppm (s, 3H); ir (KBr) 3230 (m, N-H), 3090 (w), 3000 (w), 2940 (w), 1746 and 1715 (s, C=O), 1255 and 791 cm⁻¹ [m, Si(CH₃)₂]; ir (CHCl₃) $\nu_{\text{C=O}}$ 1749 cm⁻¹ (s); mass spectrum (70 eV) m/e (rel intensity) 305 (1%), 304 (1.5%), 263 (26%), 262 (100%).

Anal. Calcd. for C₁₉H₁₉NOSi: C, 74.71; H, 6.27; N, 4.59. Found: C, 74.70; H, 6.24; N, 4.58.

Hydrogenation of 1,1-dimethyl-2,5-diphenylsilole (90) (A,B)
over palladium on carbon

A suspension of silole 90 (2.50 g, 9.55 mmol), ethyl acetate (75 ml) and 10% palladium on carbon (0.40 g) was subjected hydrogen gas. Progress of the hydrogenation was monitored by gas chromatography (10 ft x 0.25 in, 15% SE 30 on Chromosorb W, column temp 250°, head pressure 40 psi) and stopped when the silole 90 peak disappeared (retention time 17.25 min). Two new peaks appeared in the ratio of 10 (retention time 13.75 min): 1 (retention time 11.5 min). The catalyst was removed by filtration followed by removal of the ethyl acetate under vacuum which gave a yellow oil. Chromatography on silica gel with hexane resulted in separation of a residual amount of silole 90 and gave a mixture composed of 92% (from nmr) silacyclopentene and 1,1-dimethyl-2,5-diphenylsilacyclopentane: 164 nmr (CCl₄) δ 7.6-6.7 (m), 3.25-2.45 (m, 3H), 0.30 (s, 3H), -0.08 ppm (s, 3H), irradiation at 421 Hz caused a dramatic change in the 3.25-2.45 ppm region; high resolution mass spectrum calculated for C₁₈H₂₀Si: m/e = 264.133. Found: 264.132.

Conversion of silacyclopentene 164 to epoxide 166

A mixture containing 92% silacyclopentene 164 and 1,1-dimethyl-2,5-diphenylsilacyclopentane (0.10 g, 0.34 mmol) was added to a stirred solution of 85% m-chloroperbenzoic acid (0.065 g, 0.32 mmol) and chloroform (3 ml). The

resulting solution was stirred overnight at room temperature, the precipitated m-chlorobenzoic acid removed by filtration and the resulting solution was washed successively with 10% sodium bicarbonate (2 x 5 ml), water (5 ml) and saturated sodium chloride (3 ml). This solution was dried (calcium chloride) and chloroform removed under vacuum which gave a light yellow oil (0.08 g). Preparative thick layer chromatography (silica gel PF₂₅₄, 10% ether-hexane, 20 x 20 cm plate) led to observation of 3 bands: band 1, origin, band 2, 6.5 cm; band 3, 9.2 cm. Recovery of band 2 gave an oil which spontaneously crystallized. Three recrystallizations from hexane gave epoxide 166 as a white solid: mp 75-77°; nmr (CCl₄) δ 7.30-6.80 (m, 10H), 3.37 (narrow m, 1H), 2.40 (m, 3H), 0.27 (s, 3H), 0.05 (s, 3H); ir (KBr) 3065 (w), 3030 (w), 2925 (w-m), 2855 (w), 1600 (m), 1498 (s), 1450 (m), 1407 (m), 1255 (m), 1221 (m), 1135 (w), 1081 (m), 1030 (w-m), 955 (w), 909 (m), 880 (w), 842 (s), 804 (s), 789 (s), 761 (s), 751 (m-s), 702 cm⁻¹ (s); mass spectrum (70 eV) m/e (rel intensity) 280 (64%), 265 (32%), 206 (64%), 189 (100%), 165 (26%); (16 eV) 280 (100%), 206 (16%), 189 (20%), 165 (13%); high resolution mass spectrum calculated for C₁₈H₂₀OSi: m/e = 280.1278. Found: 280.1276.

Attempted reaction of 1,1-dimethyl-2,5-diphenylsilacyclopent-2-ene 164 with CSI

A solution of 92% silacyclopentene 164 (0.135 g, 0.510

mmol) and deuteriochloroform (0.3 ml) was placed in an nmr tube. Freshly distilled CSI (0.073 g, 0.516 mmol) was added to the contents of the tube and shaken vigorously. An nmr spectrum immediately after addition showed that no reaction had occurred. The tube was then heated at 75° and spectra recorded at 1.8 and 24 hr intervals. No change in the spectra was detected.

The purity of the CSI used in the above reaction was checked by the following procedure. A solution of 2-methyl-2-butene (0.70 g, 90.6 mmol) and deuteriochloroform (0.3 ml) was placed in an nmr tube and CSI (0.129 g, 0.91 mmol) added. The nmr showed no remaining starting olefin but only the nmr of 1-chlorosulfonyl-3,4-trimethyl-2-acetidinone (43): nmr δ 3.32 (q, 1H, \underline{J} = 7 Hz), 1.79 (s, 3H), 1.67 (s, 3H), 1.33 ppm (d, 3H, \underline{J} = 7 Hz).

LITERATURE CITED

1. R. Graf, Chem, Ber., 89, 1071 (1966).
2. K. Clauss, Justus Liebigs Ann. Chem., 722, 110 (1969).
3. I. Kanesaka and K. Kawai, Bull. Chem. Soc. Jap., 43, 3298 (1970).
4. R. Graf, Angew. Chem. Internat. Edit., 7, 172 (1968).
5. E. J. Moriconi, C. C. Jalandoni, J. Org. Chem., 35, 3796 (1970).
6. H. Vorbruggen, Tetrahedron Lett., 1631 (1968).
7. R. Hoffman and R. B. Woodward, J. Amer. Chem. Soc., 87, 2046 (1965).
8. R. B. Woodward and R. Hoffman, Angew. Chem. Internat. Edit., 8, 781 (1969).
9. E. J. Moriconi and J. F. Kelley, Tetrahedron Lett., 1435 (1968).
10. H. Bestian, H. Biener, K. Clauss and H. Heyn, Justus Liebigs Ann. Chem., 718, 94 (1968).
11. L. A. Paquette, M. J. Wyvratt and G. R. Allen, J. Amer. Chem. Soc., 92, 1763 (1970).
12. E. J. Moriconi and W. C. Crawford, J. Org. Chem., 33, 370 (1968).
13. H. C. Brown and J. H. Kawakami, J. Amer. Chem. Soc., 92, 201 (1970).
14. H. Hoffman and H. J. Diehr, Tetrahedron Lett., 1875 (1963).
15. E. J. Moriconi and W. C. Meyer, Tetrahedron Lett., 3823 (1968).
16. E. J. Moriconi, C. F. Hummel and J. F. Kelley, Tetrahedron Lett., 5325 (1969).
17. P. Goebel and K. Clauss, Justus Liebigs Ann. Chem., 722, 122 (1969).

18. T. Haug, F. Lohse, K. Metsger and H. Batzer, *Helv. Chim. Acta*, 51, 2069 (1968).
19. E. J. Moriconi and W. C. Meyer, *J. Org. Chem.*, 36, 2841 (1971).
20. R. Gomper, *Angew. Chem. Internat. Edit.*, 8, 312 (1969).
21. R. Graf and H. Biener, *Angew. Chem. Internat. Edit.*, 2, 546 (1963).
22. J. R. Malpass and N. J. Tweddle, *Chem. Commun.*, 1244 (1972).
23. T. W. Doyle and T. T. Conway, *Tetrahedron Lett.*, 1889 (1969).
24. L. A. Paquette, S. Kirschner and J. R. Malpass, *J. Amer. Chem. Soc.*, 91, 3970 (1969).
25. L. A. Paquette, S. Kirschner and J. R. Malpass, *J. Amer. Chem. Soc.*, 92, 4330 (1970).
26. J. R. Malpass and N. J. Tweddle, *Chem. Commun.*, 1247 (1972).
27. E. J. Moriconi, C. F. Hummel and J. F. Kelley, *Tetrahedron Lett.*, 5325 (1969).
28. J. R. Malpass, *Chem. Commun.*, 1246 (1972).
29. L. A. Paquette and T. J. Barton, *J. Amer. Chem. Soc.*, 89, 5480 (1967).
30. L. A. Paquette, J. R. Malpass, and T. J. Barton, *J. Amer. Chem. Soc.*, 91, 4714 (1969).
31. P. Wegener, *Tetrahedron Lett.*, 4985 (1967).
32. L. A. Paquette, *Tetrahedron Lett.*, 2133 (1968).
33. L. A. Paquette and G. R. Krow, *J. Amer. Chem. Soc.*, 91, 6107 (1969).
34. L. A. Paquette and G. R. Krow, *Tetrahedron Lett.*, 2139 (1968).
35. L. A. Paquette, M. J. Broadhurst, C. M. Lee and J. C. Clardy, *J. Amer. Chem. Soc.*, 94, 630 (1972).

36. C. DePuy, *Accounts Chem. Res.*, 1, 33 (1968).
37. R. Pettit, *J. Amer. Chem. Soc.*, 76, 2597 (1954).
38. L. A. Paquette, G. R. Allen and M. J. Broadhurst, *J. Amer. Chem. Soc.*, 93, 4503 (1971).
39. R. M. Silverstein and G. C. Bassler, *Spectrometric Identification of Organic Compounds*, (John Wiley and Sons, New York, 1967), p 145.
40. T. J. Barton, R. J. Rogido and J. C. Clardy, *Tetrahedron Lett.*, 2081 (1970).
41. R. Köster, S. Arora and P. Binger, *Synthesis*, 322 (1971).
42. F. Fisher and D. E. Applequist, *J. Org. Chem.*, 30, 2089 (1965).
43. R. Graf, *Justus Liebigs Ann. Chem.*, 661, 111 (1963).
44. R. Hinman and S. Theodoropoulos, *J. Org. Chem.*, 28, 3052 (1963).
45. R. M. Acheson, *An Introduction to the Chemistry of Heterocyclic Compounds*, 2nd ed, (Interscience, New York, 1967), p 106.
46. L. Justoni, *Gazz. Chim. Ital.*, 71, 3751 (1941).
47. A. J. Nelson, Ph.D. Thesis, Iowa State University, Ames, Iowa, 1972.
48. D. J. Pasto, A. E. Chen, G. Ciurdaru and L. A. Paquette, *J. Org. Chem.*, 38, 1015 (1973).
49. H. G. Ritchey, in *Carbonium Ions*, Vol. III, edited by G. A. Olah and P. von R. Schleyer (Wiley-Interscience, New York, 1972), pp 1201-1294.
50. K. Wiberg, B. A. Hess, Jr., and A. Ash, in *Carbonium Ions*, Vol. III, edited by G. A. Olah and P. von R. Schleyer (Wiley-Interscience, New York, 1972), pp 1295-1345.
51. L. A. Paquette, G. R. Allen and M. J. Broadhurst, *J. Amer. Chem. Soc.*, 93, 4503 (1971).

52. S. Julia, M. Julia, S. Tchen and P. Graffin, Bull. Soc. Chim. France, 3207 (1964).
53. D. J. Pasto and A. F. Chen, Tetrahedron Lett., 713 (1973).
54. L. A. Paquette, M. J. Broadhurst, C. Lee and J. Clardy, J. Amer. Chem. Soc., 95, 4647 (1973).
55. D. H. Aue, University of California at Santa Barbara, personal communication, 1973.
56. J. D. Roberts and R. H. Mazur, J. Amer. Chem. Soc., 73, 2509 (1951).
57. P. von R. Schleyer, et al., J. Amer. Chem. Soc., 94, 125 (1972).
58. E. Dunkelblum, Tetrahedron Lett., 1551 (1972).
59. L. M. Jackman and S. Sternhell, Applications of Nuclear Magnetic Resonance Spectroscopy in Organic Chemistry, 2nd ed., (Pergamon Press, New York, N.Y., 1969), p 136.
60. L. A. Paquette and M. J. Broadhurst, J. Org. Chem., 38, 1886 (1973).
61. L. A. Paquette and M. J. Broadhurst, J. Org. Chem., 38, 1893 (1973).
62. M. Saunders and J. Rosenfeld, J. Amer. Chem. Soc., 92, 2548 (1970).
63. L. A. Paquette, Ohio State University, personal communication, 1973.
64. E. L. Eliel in Steric Effects in Organic Chemistry, edited by M. S. Newman (John Wiley and Sons, New York, N.Y., 1956), pp 114-117.
65. F. O. Rice and E. Teller, J. Chem. Phys., 6, 489 (1938).
66. G. L. Closs, L. E. Closs and W. A. Boll, J. Amer. Chem. Soc., 85, 3796 (1963).
67. P. Cagniant, G. Merle and D. Cagniant, Bull. Soc. Chim. France, 302 (1970).
68. I. G. M. Campbell, R. C. Cookson, M. B. Hocking and A. N. Hughes, J. Chem. Soc., 2184 (1965).

69. D. R. Weyenberg, L. H. Toporcer and A. E. Bey, *J. Org. Chem.*, 30, 4096 (1965).
70. T. J. Barton and E. E. Gottsman, *Synthesis in Inorganic and Metal-Organic Chemistry*, 3, 201 (1973).
71. R. A. Benkeser and R. A. Hickner, *J. Amer. Chem. Soc.*, 80, 5298 (1958).
72. Handbook of Chemistry and Physics, fiftieth ed., edited by R. C. Weast (The Chemical Rubber Co., Cleveland, Ohio, 1969), p c-243.
73. R. T. Conley, Infrared Spectroscopy, 2nd ed., (Allyn and Bacon, Boston, Mass., 1972), p 171.
74. W. Gerrard and K. D. Kilburn, *J. Chem. Soc.*, 1536 (1956).
75. R. V. Van Volkenburgh, K. W. Greenlee, J. M. Derfer and C. E. Boord, *J. Amer. Chem. Soc.*, 71, 172 (1949).
76. K. Sisido and K. Utimoto, *Tetrahedron Lett.*, 3267 (1966).
77. J. Weinstock, S. N. Lewis and F. G. Boardwell, *J. Amer. Chem. Soc.*, 78, 6072 (1956).
78. K. J. Crowley, *Tetrahedron*, 1001 (1965).
79. L. Friedman and H. Schecter, *J. Amer. Chem. Soc.*, 82, 1002 (1960).

ACKNOWLEDGEMENT

I would like to acknowledge my wife, Donna, and daughter, Teresa, for patience and understanding while this work was undertaken. I would also like to thank my parents whose encouragement and support were deeply appreciated.

I would like to acknowledge Dr. Thomas J. Barton for suggesting much of the research contained in this thesis and for helpful discussions. I would also like to acknowledge Dr. Philip M. Warner, Roland Kippenhan, Dr. James Nelson, and Earl Gottsman for helpful discussions.

I would especially like to thank Richard LaRose not only for his friendship, but his assistance in completing this thesis in my absence. I would also like to thank the citizens of Iowa for providing financial support for this work.